



C540c

CUES' advanced digital video inspection system

Operation Manual

[C540c-OPMAN-ENG/05]

Rev 05

October 2020



Preface

Before you begin

Please read this operation manual before using the C540c system.

The C540c system is a modular system that can be purchased as a full system package or as individual components. Contact your CUES representative to ensure you are purchasing the appropriate product for your needs.

The contents of this manual are subject to change. CUES products are under continuous development. CUES reserves the right to modify any product, including this manual, without notice and some product changes may have taken place after publication of this manual.

For the latest information about the flexiprobe product family, including all accessories, documentation and software updates, contact your local CUES dealer or visit www.cuesinc.com

Copyright © 2019 CUES Ltd. All rights reserved.

CUES is a subsidiary of SPX Corporation.

Trademarks

CUES and Accupoint are considered trademarks of Cues Inc. Radiodetection, flexiprobe, flexitrax, and flexicoiler are considered trademarks of Radiodetection Ltd. Radiodetection Ltd is a subsidiary of SPX Corporation. Due to a policy of continued development, we reserve the right to alter or amend any published specification without notice. This document may not be copied, reproduced, transmitted, modified or used, in whole or in part, without the prior written consent of CUES Inc.

Other trademarks or registered trademarks mentioned in this document belong to their respective owners.

Disclaimer

Any third-party products (including hardware, software and services) mentioned in this manual are for instructional purposes only and are not an endorsement by CUES Inc or SPX Corporation.

CUES Inc does not accept any liability for loss of data or damage to equipment when using any third-party products.

Compliance

EU Compliance

This equipment complies with the following EU Directives:

- EMC Directive: 2014/30/EU
- EMF Directive: 2013/35/EU
- Low Voltage Directive: 2014/35/EU
- RoHS Directive: 2011/65/EU
- WEEE Directive: 2012/19/EU

Industry Canada Compliance

ICES-003 Class A Notice:

This Class A digital apparatus complies with Canadian ICES-003.

Avis NMB-003, Classe A:

Cet appareil numérique de la classe A est conforme à la norme NMB-003 du Canada

Ingress Protection Marking

This system complies with this rating for IEC standard 60529, solid particle and liquid ingress protection:

- IP55: Controller covers and connection panels open or closed.

FCC 15 Compliance

This equipment complies with Part 15 of the FCC Rules. Operation is subject to the following two conditions:

- The equipment may not cause harmful interference.
- The equipment must accept any interference received, including interference that may cause undesired operation.

This equipment has been tested and found to comply with the limits for a Class A digital device pursuant to Part 15 of the FCC Rules. These limits are designed to provide reasonable protection against harmful interference when the equipment is operated in a commercial environment. This equipment generates, uses, and can radiate radio frequency energy and, if not installed and used in accordance with the manufacturer's instruction manual, may cause harmful interference with radio communications. Operation of this equipment in a residential area is likely to cause harmful interference, in which case you will be required to correct the interference at your own expense.

Any modifications made to this equipment not approved by CUES may void the authority granted to the user by the FCC to operate this equipment.

Warnings, Cautions and Notes

Please observe all warnings, cautions and notes in this manual before operating any CUES product.

Warning! *Warnings alert you to possible personal injury.*

Caution: *Cautions alert you to possible equipment damage.*

Note: *Notes contain useful information.*

Warning symbols



General Warning: Refer to the manual for specific instruction or advice.



Electrical Hazard: Observe safe practices and exercise extreme caution.



Biohazard: Disinfect after use. Wear appropriate personal protective equipment (PPE).



Hot Surface: Allow to cool or use appropriate protection when handling.



Heavy object: Take additional care when lifting.

Perform a risk assessment



Warning: *Always carry out a risk assessment of the site to be inspected. This equipment is NOT approved for use in areas where potentially explosive (or otherwise hazardous) gases, vapors, liquids or solids may be present.*

CUES has taken care to provide the necessary information in this manual for the safe installation, operation, maintenance and disposal of this equipment. However, you must carry out a risk assessment before starting work as it may identify other safety issues.

Always follow standard safety precautions for working in hostile environments, including precautions for manual handling, biological hazards and personal injury.

Safety precautions

Electrical precautions



Warning: *If the system connects to mains operated equipment, the external equipment must be earthed in accordance with the manufacturer's instructions. Failure to comply with this may cause the system to become live and a **lethal hazard**.*



Warning: *System components must **not** be connected or disconnected when the power is on. Do not touch any connectors while the system is live*



Warning! *Always remove the fuse when the controller is transported by air!*

Always ensure that cabling is properly connected.

Always switch the system on and off using the controller power button.

Make sure that video and power cables are not entangled in the reel. Cable ties are recommended and will not impede system performance.

The C540c system requires a connection to a protective earth; if in doubt, consult a qualified electrician. Electrical equipment is factory-tested for electrical safety. Routine inspection is recommended (and may be required by law) to maintain this level of protection. If you are unsure, contact your local safety authority for advice.

Please observe your company, region and country's Standard Code of Practice for surveying underground utilities with CCTV equipment when using this equipment.

Biological precautions



Warning: *Foul systems can be a source of serious biological hazards. Wear appropriate personal protective equipment (PPE) when handling the C540c.*

Always use heavy-duty industrial gloves when withdrawing a rod from a sewer.

Pushrod reel precautions



Warning: *The coiled rod retains a large amount of energy when coiled and can cause injury if not correctly handled. Only competent personnel should handle this product.*



Warning: *Use the camera distance counter as an estimation only. CUES recommends that you use a Sonde and CUES cable locator to accurately locate positions of interest, especially before starting construction works.*

Wear appropriate personal protective equipment (PPE), such as eye and hand protection.

CUES recommends that a risk assessment is undertaken before the rod is handled, the bindings are cut or when using, loading, unloading, uncoiling or coiling rod.

CUES accept no liability for injury or damage to equipment incurred whilst using, loading, unloading, uncoiling or coiling the rod.

Battery precautions

The controller contains a Li-Ion rechargeable battery. Only use charging equipment provided by CUES. The use of alternative chargers may cause a safety hazard and/or reduce the life of the battery.

The battery is designed to protect itself against over-discharge, overcharge and short circuit between charge terminals. Other batteries may not provide these safety circuits.



Warning: *Exposing the controller's Li-Ion battery to high temperatures (over 140°F or 60°C) may activate safety systems and cause a permanent battery failure.*

Caution: *Do not tamper with, or attempt to disassemble, the battery.*

Caution: *If battery failure is suspected, return the entire system to an authorized repair center for investigation and repair. Local, national or IATA transport regulations may restrict the shipment of faulty batteries. Check with your courier for restrictions and best practice guidelines. Talk to a CUES sales representative for authorized repair centers.*

Caution: *Waste Li-Ion batteries must be disposed of properly, use an approved recycling facility for electronic waste.*

Camera precautions



Warning: *The camera will get hot with use. This is normal. To avoid risk of burns, do not touch the camera when it is switched on or immediately after switching it off. Leave time for it to cool before handling. Exercise care when handling the camera; consider using gloves.*



Warning: *The camera LEDs are very powerful. Do not look directly at the LEDs or point them at other people.*

Moving or transporting the system



Warning: *Some components of the C540c system are heavy. If available, use the wheels to assist transport. Observe heavy-lifting safety practices when lifting any component of this system. For the system weight and dimensions, see the specifications on [page 179](#).*



Warning! *Always remove the fuse when the controller is transported by air!*

Disposal

Do not dispose of this product in municipal waste facilities. Please check local regulations for disposal of electronic products, batteries and hazardous waste.

C540c complies with the requirements of 2012/19/EU Waste Electrical and Electronic Equipment.

Contents

C540c Operation Manual.....	1	1.3 Safety notices.....	20
Preface.....	2	1.4 Training	20
Before you begin.....	2	1.5 Updates and latest information	21
Copyright © 2019 CUES Ltd. All rights reserved.....	3	1.6 CUES technical support.....	21
Compliance.....	4	2 Quick Start.....	22
Warnings, Cautions and Notes.....	6	3 System overview.....	24
Perform a risk assessment.....	7	3.1 Controller.....	24
Safety precautions	8	3.1.1 Controller front view	25
Disposal.....	11	3.1.2 Controller rear view	27
Contents.....	12	3.1.3 Handle-mounted status indicators ..	28
1 Introduction	17	3.1.4 Main connection panel	29
1.1 C540c features.....	18	3.1.5 Auxiliary connection panel.....	30
1.2 Definitions.....	19	3.1.6 Panel buttons	31
		3.2 Controller home screen	32
		3.3 Controller battery	34
		3.3.1 Battery care.....	34
		3.3.2 Temperature	34
		3.3.3 Battery life	35

3.4 Pushrod reels.....	36	4.4.2 Sondes.....	50
3.4.1 Reels	36	4.4.3 Universal flexi.....	51
3.4.2 Reel features	37	4.4.4 Skids	52
3.4.3 Cameras.....	38	4.4.5 W-Skids	56
3.4.4 Flexi and Sondes	39	4.5 External video equipment	57
3.4.5 Skids.....	40	4.6 Battery.....	57
3.5 Accessories.....	41	4.6.1 Charge the battery before using the controller	58
4 System assembly	42	4.6.2 If the battery has low charge	59
4.1 Clamp assembly	42	4.6.3 Power the controller from a vehicle	60
4.2 Controller	44	4.6.4 How long does it take to recharge the battery from my vehicle?.....	60
4.2.1 Mounting on the reel	44	4.6.5 Replacing the battery	61
4.2.2 Power	44	5 System setup	62
4.2.3 Internal storage.....	44	5.1 Insert the fuse.....	62
4.2.4 USB memory stick	45	5.2 Power on the controller.....	63
4.2.5 Keyboard	45	5.3 Setup wizard: Set controller preferences and company details	64
4.2.6 Headset	45	5.4 Calibrate the reel	68
4.3 Pushrod reel.....	46	5.5 Configure the system settings.....	69
4.4 Cameras and accessories.....	47		
4.4.1 Camera.....	47		

5.5.1 Using the Settings menus	70	6.4 Zero the camera distance	103
5.5.2 Controller settings	72	6.5 Record a video	105
5.5.3 Screen overlay settings.....	74	6.5.1 Video format and size	105
5.5.4 Equipment settings	77	6.5.2 About the panel buttons	106
5.5.5 Reporting settings.....	78	6.5.3 On-screen recording indicators	107
5.5.6 Network settings	79	6.5.4 Quickly record a new video	108
5.5.7 Email settings	84	6.5.5 Set up a new survey and record a new video	109
5.5.8 Dropbox Settings	85	6.5.6 Record a further video for the survey currently open	111
5.5.9 Maintenance	88	6.6 Video tools.....	112
5.5.10 Company details	91	6.6.1 Pause, resume and stop recording	112
5.6 Import a company logo.....	92	6.6.2 Rotate the video feed	113
5.7 Set up a video title page.....	93	6.6.3 Take a photo	113
5.7.1 Can I set a custom title page?.....	94	6.6.4 Add Text pages.....	114
5.7.2 Design the video title page.....	95	6.6.5 Add overlay text and shapes to video segments	116
5.7.3 Enable the video title page.....	97	6.6.6 Record an audio commentary	119
6 Operating the system	99	6.6.7 Listen to an audio commentary	120
6.1 Before you begin.....	99	6.6.8 Use a Sonde	120
6.2 Calibrate the reel.....	100		
6.3 Deploy the camera	102		

6.7	Replay a video	121	7.4.3	Connect to the internet.....	139
6.7.1	Fast forward and rewind	122	7.4.4	Switch to a different WiFi network	140
6.7.2	Adjust the playback volume	122	7.4.5	Select surveys for export.....	141
6.8	Take a photo directly.....	123	7.4.6	Export to USB	142
6.9	Turn off the camera.....	126	7.4.7	Export as email attachments	143
6.10	Retrieve the camera.....	127	7.4.8	Email send failure.....	145
7	Surveys	128	7.4.9	Manage email recipients	149
7.1	Create a new survey	128	7.4.10	Export to Dropbox	151
7.2	Edit survey screen.....	131	7.4.11	Where is my survey in Dropbox?	153
7.3	Manage existing surveys.....	132	7.5	Observations	154
7.3.1	Open a survey	133	7.5.1	Condition codes	155
7.3.2	Search for a survey.....	133	7.5.2	Add an observation	156
7.3.3	Sort surveys by title or date	134	7.5.3	Jump to observations when playing back a video.....	158
7.3.4	Delete surveys.....	134	7.5.4	View or edit an observation	159
7.3.5	Rename a survey.....	135	7.5.5	Delete observations	160
7.3.6	Edit the survey header details.....	136	7.5.6	Clock references	162
7.4	Export a survey	137	7.6	Reports.....	163
7.4.1	What is exported?.....	137	7.6.1	Drain and sewer diagrams	164
7.4.2	Export options.....	138	7.6.2	Manhole and inspection chamber diagrams	165

7.7 Video streaming	166	11 Open Source Software.....	182
7.8 Menu shortcuts	168	Index.....	183
7.9 Supported survey standards	169	Contact us	191
7.9.1 WinCan-compliant surveys – option.....	170		
8 Maintenance and cleaning.....	172		
8.1 Maintenance	172		
8.1.1 Storing the system.....	172		
8.1.2 Connection points, terminals and O-rings.....	173		
8.1.3 Rod guide assembly	174		
8.2 Cleaning the system.....	175		
8.3 Factory reset.....	176		
9 Software updates	177		
10 Specifications	179		
10.1 Controller specifications	179		
10.2 Reel and rod specifications	180		
10.3 Camera specifications.....	181		

1 Introduction

The C540c is an advanced pushrod inspection system. It allows operators to precisely identify and document pipeline faults using digital video recording.

Lightweight, rugged and weatherproofed, the system is designed for use in harsh conditions. It is easy to transport and deploy, enabling quick and successful inspections.

The C540c controller can drive any combination of compatible pushrod reels and cameras. Its 10" (26cm) screen displays the camera's video feed, stored videos and photos, and configuration settings. You operate the controller using its built-in buttons and keyboard.

If required, you can connect the controller to external video equipment (input and output), to a headset with microphone, and to an external keyboard.



Fig. 1.1: C540c controller and pushrod coiler

1.1 C540c features

The C540c pushrod inspection system offers the following features:

- One-touch video recording to MP4 format.
- One-touch still images captured to JPEG format.
- Rotate the video feed while recording live video.
- Survey data stored on high capacity (128GB) built-in solid state storage.
- Rechargeable battery and external power supply options.
- Integrated survey reporting.

Survey reports, videos and observation photos, can be exported to USB memory sticks, sent as email attachments or uploaded to Dropbox. MSCC3 through MSCC5 survey standards are supported. WinCan-compliant surveys can also be performed, subject to additional licensing.

- Modular system, fully compatible with the full range of flexiprobe C540 cameras, Sondes, accessories and reels, from the 100' (30m) Plumbers system to the 500' (150m) flexiprobe 543 reel.

1.2 Definitions

When using a pushrod system, you need to understand the following concepts:

- **Calibration:** To accurately measure and display camera distances, you must calibrate the reel (coiler) each time you power on the controller or attach a different pushrod. First, you must make sure *the pushrod is fully rewound on the reel*. Then you must press the **Calibrate** button on the controller. See [page 99](#).

Calibration is also known as *calibrating the rod counter*.

- **Zero distance:** Your survey needs to accurately record the distance of the camera from the starting manhole so that pipe defects and features can be accurately located. However, in most cases you will need to unwind the pushrod some distance so you can deploy the camera down into a manhole before starting the pipe survey.

To ensure camera distances are recorded accurately in your survey videos and observations, you need to zero the camera distance ('set a zero distance') when the camera is in position before you start the survey. See [page 103](#).

Setting a zero distance is also known as *zeroing the rod counter*.

1.3 Safety notices

Caution must be taken when conducting any pipeline or drainage system inspection. Please observe all safety warnings detailed in the Preface (see [page 8](#)) and throughout this operation manual.

Before you operate the C540c system, we recommend that you familiarize yourself with any additional health and safety requirements that may be defined by company policy and any applicable local or national laws. Contact your company's or local government's health and safety officer for further information.

1.4 Training

CUES provides training services for most CUES products. Our qualified instructors will train equipment operators or other personnel at your preferred location or at CUES facilities. Training in best practices can lead to improved efficiency, avoid workplace accidents, how to diagnose and repair simple issues, as well as facilitating longer product lifetimes.

For more information go to www.cuesinc.com or contact your local CUES representative.

1.5 Updates and latest information

CUES may have released new system software, user documentation or other information after you purchased your system. You can download the latest software, documentation and application notes from www.cuesinc.com

For information about checking and upgrading your system's software, see [page 177](#).

1.6 CUES technical support

If you need technical assistance, please contact DL-PP.Service.US@spx.com

Or visit www.cuesinc.com

2 Quick Start

Note: *This section provides quick start instructions for experienced users only. We recommend that new users read this manual fully before proceeding.*

To get started with the C540c system, follow these steps:

- 1 Make sure the controller is powered off.

Note: *This Quick Start section assumes that the controller battery is charged. For details about charging the battery, see [page 57](#).*

- 2 **Important!** Rewind the pushrod completely onto the reel.
- 3 Set up the controller:
 - a. (Optional) Mount the controller onto the reel using the supplied clamp; see [page 42](#).
 - b. Connect the pushrod reel to the controller using the link cable (item 4 on [page 29](#)).
- 4 Press the power button to switch on the controller.

The controller takes around 15 seconds to display the first screen.

5 *Important!* The controller displays the Equipment settings menu. Check that the correct reel type is selected. Follow these steps:

If the Equipment settings menu is showing the reel type currently attached to the controller, then press Select. Otherwise, change the reel type, highlight **Continue**, then press **Select**.

- c. The controller now displays an advisory reminding you to rewind the pushrod fully onto the reel (coiler). Make sure the pushrod is layered evenly and correctly onto the reel.
- d. When the rod is fully coiled on the reel, press the **Calibrate** button.

For full details about these steps, see [page 100](#).

6 Deploy the camera into the pipe as required.

7 Zero the camera distance, as required, using the **0.00** button.

For details, see [page 103](#).

8 Create a survey and start recording your survey video.

For details, see [page 128](#).

3 System overview

The C540c pushrod inspection system comprises of a controller, pushrod reel, camera and accessories.

3.1 Controller

The C540c controller is the command module and digital video recorder and playback device. Video is displayed on a 10.1" (26 cm) industrial TFT LCD screen. Video, pictures and inspection reports are stored on a high-speed, high capacity (128GB) internal solid state storage.

The C540c controller is compatible with the full range of C540 cameras, reels, Sondes and accessories, providing unmatched modularity from the small 100' (30m) Plumbers system to the 500' (150m) flexiprobe 543 Mk2 reel.

The C540c controller has an internal, rechargeable lithium-ion battery. A fully charged battery will power the controller for around 4 to 6 hours.

3.1.1 Controller front view

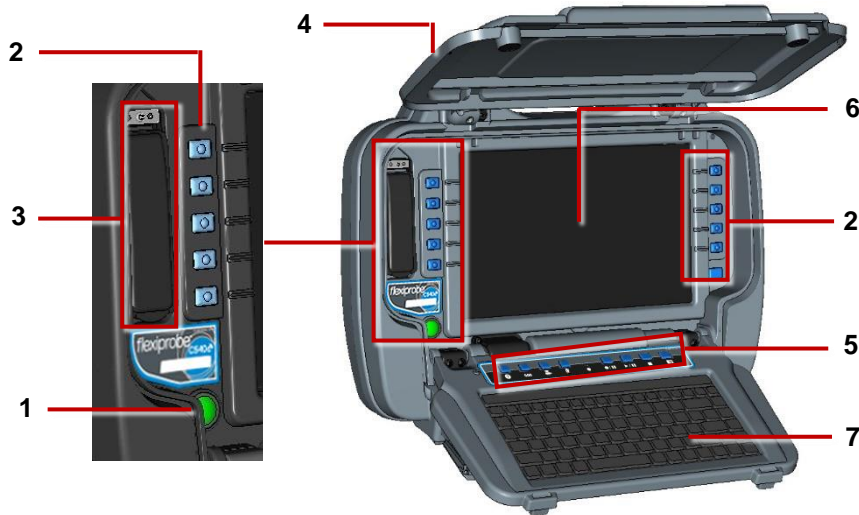

Fig. 3.1: Controller, front view

1 **On/Off button:** Switches power ON or OFF.

When the system is powered on, the on power indicator on the handle lights up.

2 **Buttons:** Allow you to navigate screen menus and control the system.

- 3 **Protected USB and audio sockets:** The covered compartment contains a USB socket and audio socket. The cover protects against water and dust.

Use the USB socket to connect a USB memory stick (for example, to install software upgrades).

Use the 3.5mm audio socket to connect a headset with microphone for adding an audio commentary to survey videos.

- 4 **Handle-mounted status indicators:** On the back and front of the handle, LEDs indicate the controller's WiFi, Power and Battery Charge status; see [page 28](#).

- 5 **Panel buttons:** Allow you to record survey videos, make observations and take photos, mute the microphone, and zero the camera distance; see [page 31](#).

- 6 **Display:** LCD screen shows video, still images and system information.

- 7 **Keyboard:** Use for text entry when setting up surveys and configuring the controller.

3.1.2 Controller rear view

On the rear of the controller are the main and auxiliary connection panels, and the support clamp.

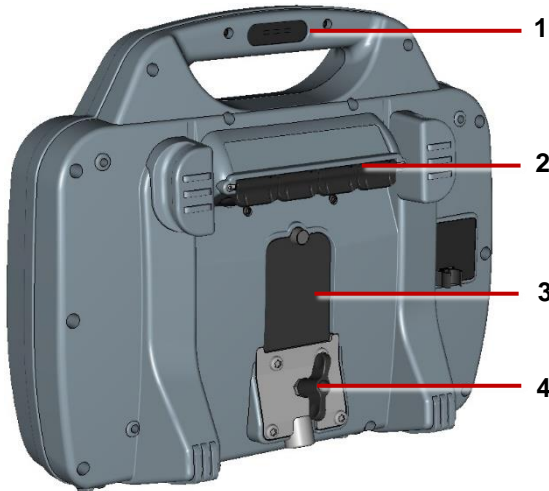

Fig. 3.2: Controller, rear view

- 1 **Handle-mounted status indicators:** On the back and front of the handle, LEDs indicate the controller's WiFi, Power and Battery Charge status. See [page 28](#).
- 2 **Main connection panel:** Includes a socket for the link cable to the pushrod reel, an external video input, and the power socket. See [page 29](#).
- 3 **Auxiliary connection panel:** Includes an HDMI output, dual USB ports, and a battery fuse. See [page 30](#).
- 4 **Controller support clamp:** For mounting the controller onto the reel. See also item 6 on [page 37](#).

3.1.3 Handle-mounted status indicators

On the back and front of the handle, LEDs show the WiFi, Power and Battery Charge status.

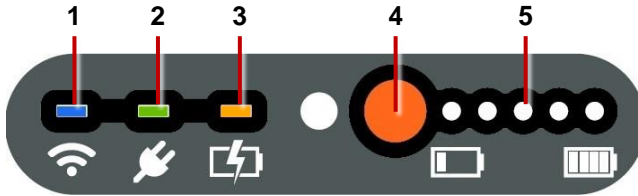

Fig. 3.3: Status indicators on controller handle (front view)

1 **WiFi:** Lights up when WiFi is enabled on the controller.

Note: *This LED indicates only that WiFi is enabled and the controller can detect available WiFi networks. It does not indicate that the controller is connected to the internet!*

2 **Power:** Lights up when the controller is powered on (green).

3 **Battery charge:** Lights up while battery charging is underway (amber). When the battery is fully charged, the LED changes to green.

Note: *Also indicates the controller is connected to an external power supply (mains or vehicle).*

4 **Battery check button:** Press to check the battery level.

5 **Charge status lights:** When the battery check button is pressed, these lights show the battery level.

3.1.4 Main connection panel

The main connection panel includes the power socket, a socket for the link cable to the reel, and an external video input. Each socket has an individual cover.

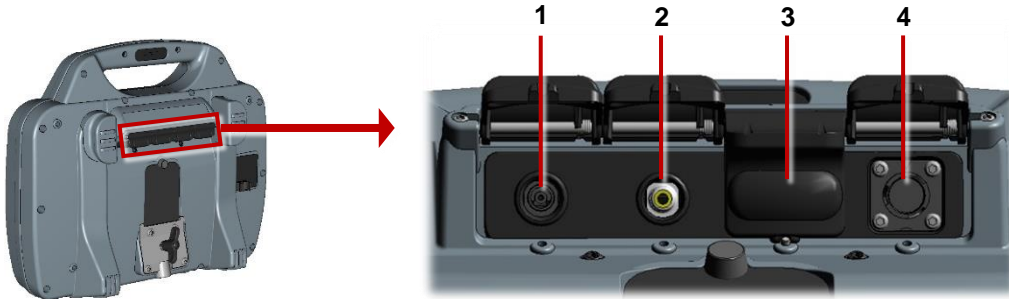

Fig. 3.4: Main connection panel

1 **Power socket:** DC power input from mains supply or vehicle supply.



Warning! Use only the supplied battery chargers (mains or vehicle).

2 **Video input:** An RCA video jack provides an input for external video equipment (optional).

3 *Reserved for future use.*

4 **Socket for link cable to pushrod reel:** Connects the controller to the pushrod camera. Tighten the connector finger-tight, but do not use a wrench, spanner or pliers.

3.1.5 Auxiliary connection panel

Caution: Only open the auxiliary connection panel in a dry, clean environment.

The auxiliary connection panel includes a video output and two USB ports:

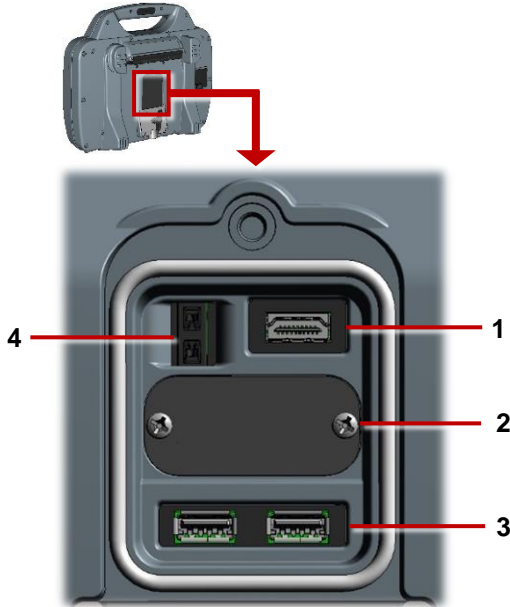

- 1 **HDMI output:** Allows you to display live video on an external monitor. (Video replay on an external monitor is not currently supported.)
- 2 *For manufacturer use only.*
- 3 **USB sockets:** Allows you to connect a USB memory stick or external keyboard.
- 4 **Fuse holder:** For a 5A MINI Blade fuse. The fuse is supplied separately with the controller; you must insert the fuse before operating the controller.

 **Warning!** You must remove the fuse to isolate the battery when the controller is transported by air!

Fig. 3.5: Auxiliary connection panel

3.1.6 Panel buttons

Use these buttons to record and play videos, take photos, set a zero distance and mute the mic.

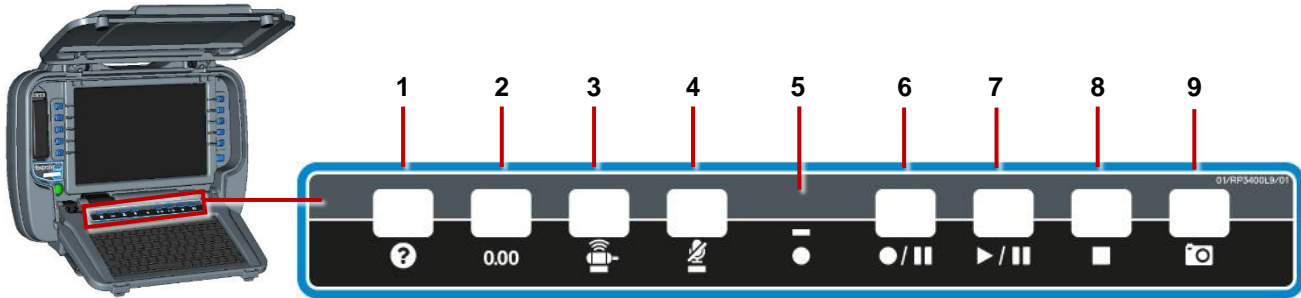



Fig. 3.6. Panel buttons

- 1 **Help:** Displays the C540c operation manual.
- 2 **Zero the camera distance:** See [page 103](#) for details.
- 3 **Sonde:** Reserved for future use.
- 4 **Mute microphone:** LED is red when microphone or headset is muted.
- 5 **Recording LED:** Red when video recording in progress.
- 6 **Record / pause:** Press to start or pause video recording.
- 7 **Play / pause:** Press to play or pause video playback.
- 8 **Stop:** Press to stop video playback or recording.
- 9 **Camera:** Press to take photo and make an observation; see [page 156](#).

3.2 Controller home screen

Note: Press the  **Back** button one or more times to return to the home screen.

The home screen lets you create and manage surveys, configure system settings, and rotate the video feed. It also shows real-time system and telemetry information (camera distance since being zeroed; see [page 103](#)). If required, you can overlay these details in your survey videos and observation photos.



Fig. 3.7: Controller home screen. A Button labels hidden. B Button labels shown. See next page for descriptions.

Controller home screen, continued

- 1 **System date and time**
- 2 **Camera distance.** Also called the distance counter or rod counter.
- 3 **Create survey button.** Press to set up a new survey.
- 4 **Existing surveys button.** Press to manage surveys stored on the controller.
- 5 **Battery charge & Survey title**
- 6 **Menu button.** Shows or hides button labels.
- 7 **Settings button.** Opens the system menus.
- 8 **Set distance button.** Press to zero the camera distance for a new survey.
- 9 **Roll camera CW and ACW buttons.** Press to rotate the video feed on the screen clockwise (9a) or anticlockwise (9b).
- 10 **Recording and mic status**
- 11 **Free disk space (GB).** Shows free space on the controller's internal solid state storage. A pie graphic shows free (green) and used (red) space.

3.3 Controller battery

The C540c controller has a lithium-ion (Li-ion) rechargeable battery.

Li-ion batteries have excellent power to weight ratios and can offer very long lifetimes. Some simple steps to prolong the life of your Li-ion battery are outlined below.

3.3.1 Battery care

- Do not **discharge** the battery too much; do not **charge** the battery too much.
Try not to discharge below 10%, or charge above 90%. This will dramatically increase the number of charge and discharge cycles that the battery can achieve.
- Only charge your battery at temperatures of 50-104°F (10-40°C). See [below for more details](#).
- Keep the power socket clean and dry at all times. Keep the main connection panel closed when the controller is not in use. See the image on [page 27](#).

3.3.2 Temperature

Battery life is affected by the temperature while charging the battery. At lower temperatures (below 50°F or 10°C), chargers will lower the charging rate to reduce battery degradation. CUES therefore recommends that you only charge the battery at temperatures of 50-104°F (10-40°C).

3.3.3 Battery life

With typical constant usage, the C540c controller battery will last around two years. For advice on replacing the battery, see [page 61](#).



Do not attempt to replace the battery yourself!

3.4 Pushrod reels

3.4.1 Reels

The reel (or coiler) holds the pushrod-and-camera on a revolving drum. The C540c system supports the reels below. See [page 180](#) for reel specifications.



Fig. 3.8: C540c pushrod reels. 1 543 reel. 2 542 reels, available in two lengths. 3 541 reels: standard reel and extra-flexible Plumbers reel.

3.4.2 Reel features

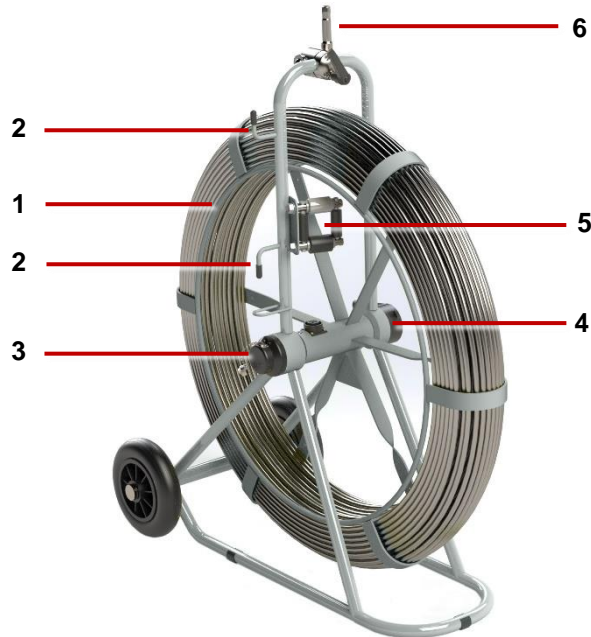

- 1 **Pushrod reel:** The pushrod can be up to 500ft (150m) in length, depending on reel type.
- 2 **Stowage hooks:** Use for storing the link cable on the pushrod reel.
- 3 **Link cable socket:** Connects the link cable to the reel.
- 4 **Brake:** *Not shown.* Located on reverse side of reel. Adjustable to control the movement of the reel, or to lock it.
- 5 **Pushrod guide:** Guides the rod on and off the reel. Must be kept clean.
- 6 **Adaptor clamp:** Allows the controller to be mounted onto the pushrod reel.

*Fig. 3.9: Reel features
This example shows a 543 reel.*

3.4.3 Cameras

Three color camera options are available:



Fig. 3.10: C540c pushrod cameras

- 1 **1" (25mm) diameter camera** for up to 4" (100mm) diameter pipes
- 2 **1¼" (32mm) diameter self-leveling camera** for up to 6" (150mm) diameter pipes
- 3 **2" (50mm) diameter self-leveling camera** for up to 9" (230mm) diameter pipes

3.4.4 Flexi and Sondes



Fig. 3.11: Universal flexi and Sondes

- 1 **Universal Flexi:** (Optional purchase) Attaches to the end of the pushrod to allow the camera to negotiate small radius bends.
- 2 **Sonde:** (Optional purchase) Attaches to the end of the pushrod and transmits a signal, allowing the Sonde's position to be pinpointed using a CUES locator such as an Accupoint MS610 or a Radiodetection RD5100S or RD7100DL receiver.
 - 2a FlexiSonde
 - 2b Solid Sonde
 - 2c (Plumbers reels only) Non-detachable Plumbers Sonde

3.4.5 Skids

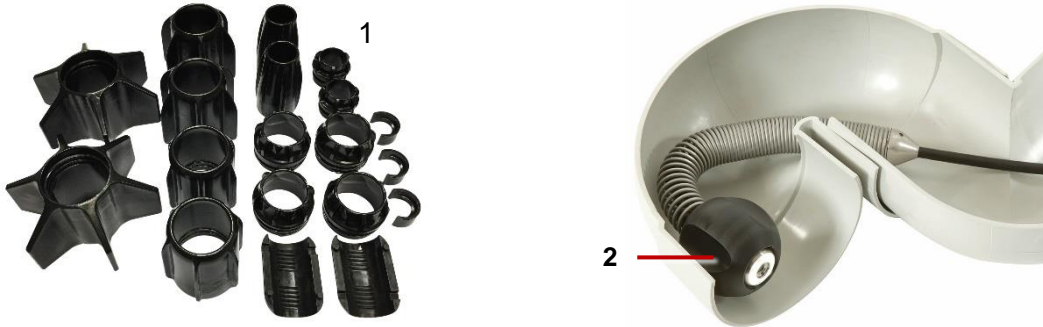

Fig. 3.12: Brushes and skids

- 1 **Universal skids:** Protect the camera during use and centers the camera in the pipe. For instructions on how to install skids and brushes, see [page 52](#).
- 2 **Plumbers skidball:** For 1" (25mm) cameras, this skidball allows movement around most 2" (50mm) traps and 1.25" (32mm) bends. Available in 1.4" (36mm) and 1.6" (42mm).

3.5 Accessories

All systems include:

- **Mains charger:** Comprises an AC adapter and a mains power cable. Used for recharging the internal Li-Ion battery and, optionally, operating the controller.
- **Vehicle charging cable:** Connects the controller to your DC power connector (typically the cigarette lighter or cigarette charging point). Used for recharging the internal Li-Ion battery and operating the controller.

Optional accessories:

- **USB memory stick:** Allows survey data, including videos and observation photos, to be exported from the controller. Also used for controller software upgrades.

Only use high-speed USB memory sticks. We recommend using only USB memory sticks produced by well-known flash memory manufacturers. For the latest list of recommended memory stocks, contact DL-PP.Service.US@spx.com

- **Headset:** Allows the operator to add and play back audio commentary.
- **Other:** CUES also provide other useful components and tools such as rod re-termination kits. Contact your CUES representative for details.

4 System assembly

This section describes the procedures used to setup the C540c for the first time. The system can be configured in many ways, depending on the components used for your survey.



Warning! *Before you assemble the system, switch off the controller.*

4.1 Clamp assembly

Use the supplied clamp to attach the controller onto the pushrod reel. If the clamp is supplied separately from the reel, follow the steps below to disassemble it and attach it to the reel:

- 1 Remove the black handle, by rotating anti clockwise. Place safely to one side.
- 2 Slide washer and collar off the shaft and place safely to one side.
- 3 Remove the 4 x 6mm bolts using a 5mm Allen key (not supplied) and set aside.
- 4 Remove the end clamp and set aside.
- 5 Place the clamp unit on the reel crossbar, with the threaded shaft lowermost and the clamp spigot pointing upwards.
- 6 Place the end clamp in the clamp unit and secure in place using the 4 x 6mm bolts.
- 7 Place the collar, then the washer, onto the threaded shaft.

8 Place the black handle back on the threaded shaft until hand-tight.
The clamp should appear as shown below.

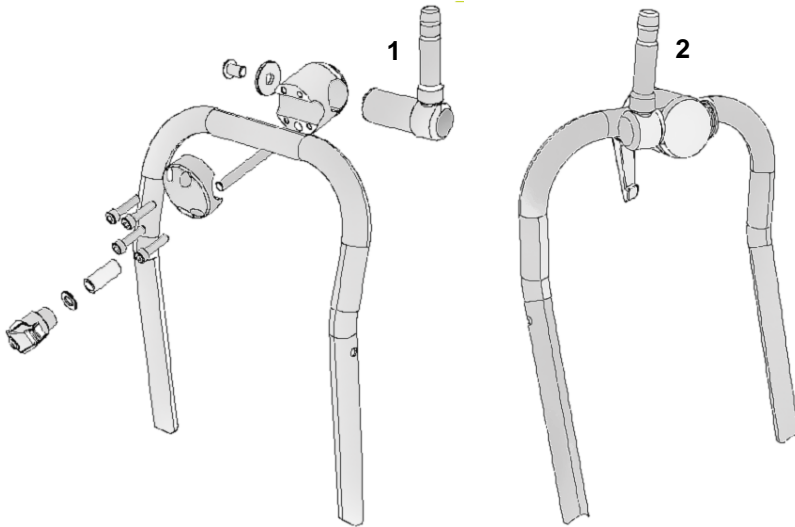

Fig. 4.1: Pushrod clamp exploded (1) and installed (2)

4.2 Controller

4.2.1 Mounting on the reel

If required, you can mount the controller on the pushrod reel with the supplied clamp; see [page 42](#).

4.2.2 Power

The C540c controller has an internal lithium-ion battery. A fully charged battery will power the controller for around 4 to 6 hours.

- To charge the battery, see [page 57](#).
- To power on the controller, see [page 63](#).

4.2.3 Internal storage

The controller has 128GB of internal solid state storage to store survey data (video recordings, photos, and reports). As a rough guide, the storage capacity is enough for 90 hours of video footage.

You can export stored survey data from the controller to a USB memory stick, as email attachments, or as uploads to a Dropbox account.

Caution: *The controller uses an SD card for storage. Do not remove or replace the SD card! Only CUES technical staff can do this.*

4.2.4 USB memory stick

You *must* use a USB memory stick (not supplied) to install software upgrades. You can *optionally* use a USB memory stick to import your company logo onto the controller and to export surveys and other data. The controller only supports FAT32 memory sticks; see [page 89](#).

You can use any USB port on the front or rear of the controller; see [pages 25 and 27](#).

4.2.5 Keyboard

Your C540c controller is supplied with the correct keyboard for your region and the controller settings are preconfigured to use this keyboard layout. However, you can manually specify a different keyboard layout if required. For example, you can select a US English, French or German keyboard layout; see [page 72](#).

(Optional) Where operating conditions permit, you can connect an external keyboard to a USB port on the auxiliary connection panel; see [page 30](#).

Note: *The controller does not support a mouse.*

4.2.6 Headset

(Optional) You can use a headset with a microphone to record and hear audio commentary in your video recordings. Connect the headset to the protected audio socket on the front of the controller (item 3 on [page 25](#)).

4.3 Pushrod reel

Note: You must select the reel type when you power on the controller; see [page 77](#).

Use the link cable to connect the pushrod reel to the controller.

On the reel, find the link cable socket on the side of the reel ([page 37](#)). Use the stowage hooks on the back of the C540c controller and Velcro cable tidies to secure the cable.

On the controller, the link cable socket is on the main connection panel ([page 29](#)).

Tighten the connectors finger-tight but do not use a wrench, spanner or pliers.



Fig. 4.2: Link cable (1) connects to the pushrod reel (2)

4.4 Cameras and accessories



Warning! *When you attach or change the camera, universal flexi or Sonde, the internal electrical connectors are exposed to the elements. Always attach the cameras and accessories in a dry, clean environment.*

4.4.1 Camera

Attach the camera to the pushrod. Then focus the camera to match the pipe diameter:

- 1 Check the camera lens. Make sure there is no dirt in the lens recess. Then clean the lens with a lint-free cloth.
- 2 Fit and hand-tighten the camera to the rod termination socket.

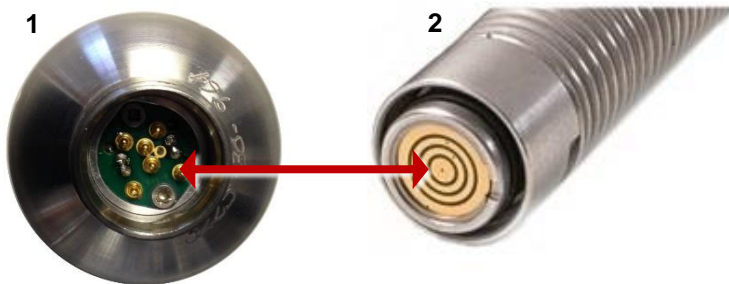

Fig. 4.3: Camera connector (1) attaches to the rod termination socket (2)

- 3 (1" and 2" cameras only) For optimal image quality, adjust the camera focus to match the internal diameter of the pipe:
- Power on the rod and make sure camera's view is displayed on the controller screen.
 - Position the camera at the required distance from a suitable target object (see Table 4.1 on [page 49](#)).
 - Use the camera's focus tool (supplied with the system) to turn the focusing ring until the target object is in focus on the controller screen.

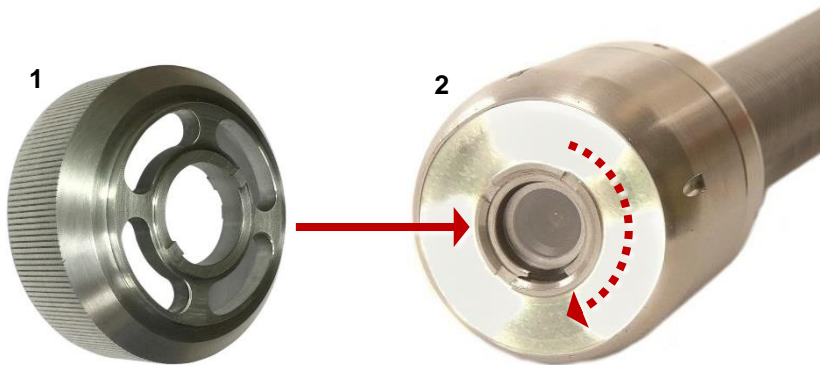

Fig. 4.4 Camera focus tool. Attach the focus tool (1) to the camera's focusing ring (2) and rotate to adjust the camera focus.

Camera	Internal pipe diameter		Target object: Required distance from camera	
	Inches	mm	Inches	mm
1" (25mm) Camera	1.25	32	3.0	76
	1.5	38	3.6	92
	2	51	4.8	122
	3	76	7.2	183
	4	102	9.6	244
2" (50mm) Camera	2	51	5.6	142
	3	76	8.4	213
	4	102	11.2	284
	6	152	16.8	427
	8	203	22.4	569
	9	229	25.2	640

Note: The 1¼" (32mm) camera has fixed (non-adjustable) focus.

Table 4.1: Focusing table for 1" and 2" cameras

4.4.2 Sondes

(Optional) Attach a Sonde to the camera. A Sonde is a self-contained transmitter for tracing the paths of pipes, sewers, ducts and drains.

By attaching a CUES flexiSonde (or solid Sonde) to your camera and using a CUES locator such as an Accupoint MS610 or a Radiodetection RD5100S or RD7100DL, you can locate and track the camera as it navigates a pipe.

- **FlexiSonde:** This Sonde (built-in on flexiprobe 541 Plumbers reels) fits between the pushrod and the camera, allowing the system to better negotiate bends in the pipe.
- **Solid Sonde:** This Sonde adds extra rigidity to the camera and it is ideal for 'long push' inspections. A solid Sonde can be used in conjunction with a *universal flexi*; see below.

Note: *The Sonde fits on the pushrod between the rod termination socket and the camera.*



Fig. 4.5: FlexiSondes (1) and solid Sonde (2)

4.4.3 Universal flexi

(Optional) Attach a universal flexi to the camera. This is a flexible spring attachment that allows the camera and pushrod to negotiate sharp bends in the pipe. The universal flexi fits on the pushrod between the rod termination socket and the camera.

Note: *The universal flexi is not required for the Plumbers system.*



Fig. 4.6: Universal flexi

4.4.4 Skids

Attach the appropriate skids to center the camera and protect it from damage.

Skids protect the camera from damage and allow it to safely navigate larger pipes. Use skids with the camera wherever possible.

You can also attach skids to ensure the axis of the camera is aligned with the central axis of the pipe. (If the camera is not centered in the pipe, videos and photos can be distorted. This can potentially cause errors when estimating water levels and the location of pipe deformations.)

Each C540c system comes with a universal skid set that allows you to adapt your camera and pushrod for deployment in pipes from 2" (50mm) to 6" (150mm). The universal skid set works with 1" (25mm) and 2" (50mm) cameras and the solid Sonde, the 1" (25mm) and 1.4" (35mm) flexiSondes, and the universal flexi. The W-skid can be used with the 2" (50mm) camera for pipe diameters up to 9" (225mm).

The diagram on [page 53](#) shows the different diameter configurations that can be achieved with the universal skid set. The subsequent pages show examples of how the 1" (25mm) and 2" (50mm) cameras fit together with the skids..

Notes

- *CUES recommends using two skids to help keep the camera level.*

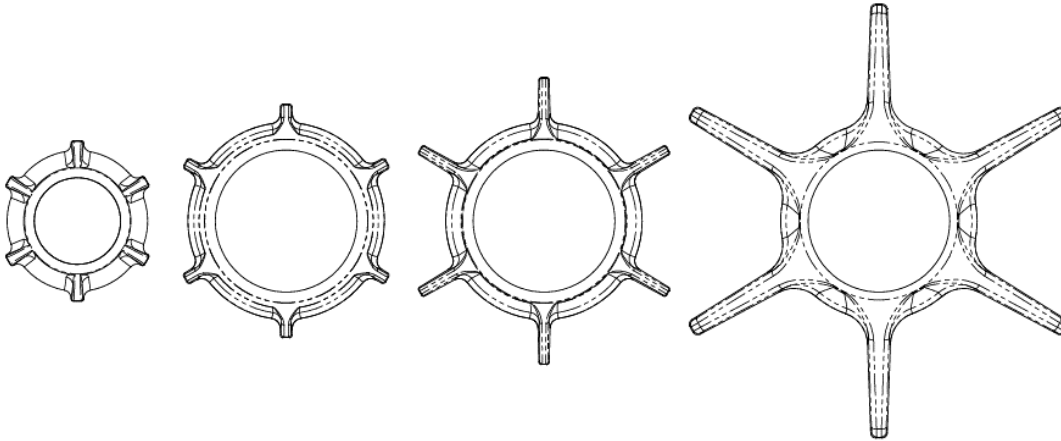

Fig. 4.7: Different diameter configurations that can be achieved using the universal skid set

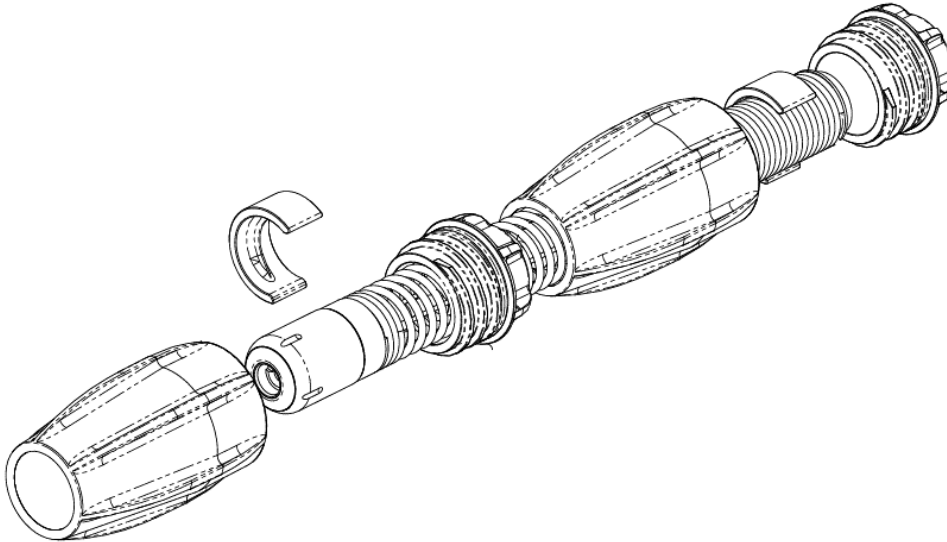

Fig. 4.8: Universal skid set for 1" (25mm) camera and flexiSonde

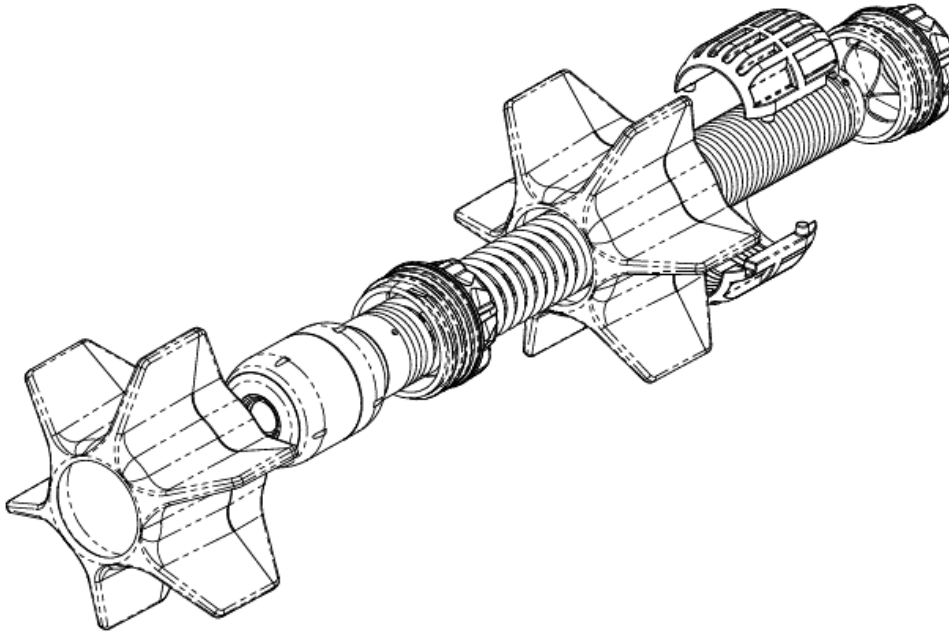

Fig. 4.9: Universal skid set for 2" (50mm) camera and 1.4" (36mm) flexiSonde

4.4.5 W-Skids

(Optional) Use the 8" (200mm) W-Skids to center a 2" (50mm) camera in an 8" (200mm) pipe or to help center the camera in larger pipes. To install the W-Skids:

- 1 Position each of the three W-Skids onto the collar and fix firmly with two M5 x 12mm screws each. The skids are asymmetrical and can only be fitted one way round.
- 2 Loosen the two M6 x 20mm screws that hold the two halves of the collar together and insert the flexiSonde with the camera attached into the collar.
- 3 Make sure the camera is touching the screw end of the collar. Then tighten the two M6 x 20mm screws evenly and firmly to re-tighten the collar.

4.5 External video equipment

You can connect external video recording or playback equipment to the controller using the video jack on the main connection panel (item 4 on [page 29](#)).



Warning! *Any connected equipment must be earthed in accordance with the equipment manufacturer's documentation. Failure to comply may result in electric shock and damage to the C540c system.*

4.6 Battery

The C540c controller has an internal lithium-ion (Li-ion) battery.

You must fully charge the battery before using the system for the first time. You can also power the controller from a 12-24V DC vehicle supply.

A fully charged battery will power the controller for around 4 to 6 hours. The actual battery life will depend on usage and system configuration. For example, if screen brightness is set to maximum and WiFi is permanently enabled, the battery will drain faster.

For charging the battery and replacing the battery at the end of its useful life, see [pages 58 to 61](#).

For advice on prolonging the battery life, see [page 34](#).

4.6.1 Charge the battery before using the controller



Warning! Use only the supplied battery charger (or optional vehicle charge lead). Do not plug any other CUES connectors into the controller power socket.

You must fully charge the controller's internal battery before using the system for the first time. To charge the battery:



- 1 Use the supplied mains adapter ('power brick') to connect the controller to the mains power supply. The controller's power socket is on the main connection panel on the rear of the controller.
- 2 Allow 4 to 6 hours for the battery to be fully charged. While charging is underway, the  battery charge LED on the controller's handle is amber (see [page 28](#)).
- 3 When the battery is fully charged, the  battery charge LED is green and the battery indicator on the home screen ([page 32](#)) is also solid green.



Fig. 4.10: Power socket (1) on main connection panel

4.6.2 If the battery has low charge

Caution: *We recommend you use an alternative power source when the battery charge is low to avoid losing survey data. A low battery may also cause the power to cycle repeatedly.*

The current battery charge is always shown on screen. For example, see the home screen on [page 32](#). You also can check the battery level at any time by pressing the **Battery check** button ([page 28](#)).

If the battery charge is low, you can:

- Adjust the Power Management settings. For example, you can set timeouts to automatically dim the screen or power off the pushrod after a period of inactivity. See [page 88](#).
- Adjust key settings to reduce battery usage. For example, if screen brightness is set to maximum and WiFi is permanently enabled, the battery will drain faster
- Connect the supplied battery charger (or optional vehicle charge lead).

4.6.3 Power the controller from a vehicle



Warning! *Use only the supplied vehicle charging cable. Do not plug any other automotive chargers into the controller power socket.*

If the controller has low battery charge, you can still operate it while powering it from your vehicle. The vehicle charging cable is 18ft (5.5m), but if the survey site prevents you parking the vehicle close to the manhole or pipe that you need to survey, you can recharge the controller battery from your vehicle.

Use the supplied vehicle charging cable to connect the controller to your vehicle's DC power connector (typically the cigarette lighter or cigarette charging point). The controller's power socket is on the main connection panel on the rear of the controller; see [page 58](#).

4.6.4 How long does it take to recharge the battery from my vehicle?

This depends on several factors, including whether the controller is powered on and the condition of your vehicle battery. Also, some vehicles switch off the DC power connector while the ignition is off.

But as a rough guide, if the controller is powered off, then 60 minutes of recharging from your vehicle's DC power connector (for example, while driving to the survey site or during a lunchbreak) can restore the controller battery level by up to 25%.

Consider also the power management options to preserve battery life; see [page 88](#).

4.6.5 Replacing the battery



Do not attempt to replace the battery yourself!

With typical constant usage, the controller battery will last around two years. If the battery reaches the end of its useful life and you can no longer recharge it, the battery must be replaced by CUES technical support; see [page 21](#). Or contact your CUES representative.

5 System setup

When you power on the controller for the first time, you must carry out various setup tasks. Make sure you complete these tasks before you start any pipeline surveys.

5.1 Insert the fuse

A 5A 32V MINI blade fuse is supplied separately with the controller. You must insert the fuse before powering on the controller for the first time.

Open the cover of the auxiliary connection panel and insert the fuse into the fuse holder. Then close the cover.

 **Warning!** *You must remove the fuse to isolate the battery when the controller is transported by air!*

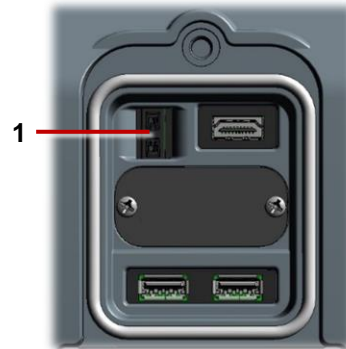

Fig. 5.1: Fuse holder (1) in auxiliary connection panel.

5.2 Power on the controller



Warning! *The controller is not earthed. If system connects to any mains operated equipment, the external equipment **must** be earthed in accordance with the manufacturer's instructions. Failure to earth the attached equipment may result in potentially lethal electric shock.*

To power on the controller:

- 1 Open the two covers.
- 2 Press the power button to switch on the controller ([page 25](#)).

The  power LED on the handle is green when the controller is powered on.

- 3 The controller takes around 10 seconds to display the first screen:
 - When you power on the controller for the first time, the setup wizard launches; continue to [page 64](#).
 - When you power on the controller on all subsequent occasions, the controller first prompts you to calibrate the reel; continue to [page 68](#).

5.3 Setup wizard: Set controller preferences and company details

When you power on the controller for the first time, or after performing a factory reset (see [section 8.3](#)), a setup wizard launches automatically. The wizard comprises several menus where you can set preferences and company details.

Follow these steps:

- 1 Power on the controller for the first time.

The setup wizard launches automatically.

- 2 Select the controller language.

- 3 Select the **Continue** menu item to display the next setup wizard menu.

(Use the **Up** and **Down** buttons or press the $\uparrow\downarrow$ arrow keys to select menu items.)



Fig. 5.2 Basic Configuration: Language. 1 Continue menu item.

- 4 Select the controller date and time, date format and time zone. Then select the **Continue** menu item. The date and time are shown on the controller screen and, optionally, overlaid on video recordings; see [page 74](#).

Note: You will need to manually adjust the controller's time to account for daylight saving time (DST) clock shifts in your area.

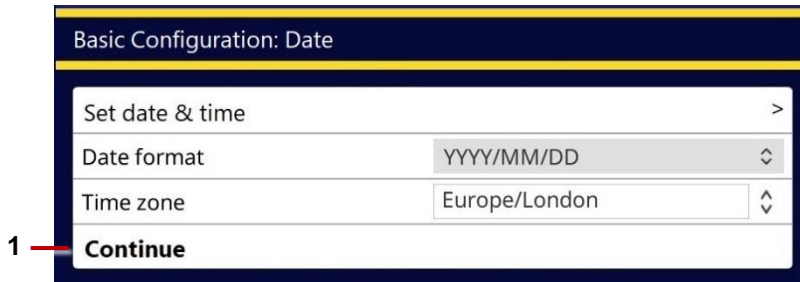

Fig. 5.3 Basic Configuration: Date and time. 1 Continue menu item.

- 5 Select your keyboard layout and distance units (0.0ft or 0.0m). Then select the **Continue** menu item. The camera distance is shown on the controller screen and, optionally, overlaid on video recordings; see [page 74](#). Your chosen distance units are also used when adding survey observations.

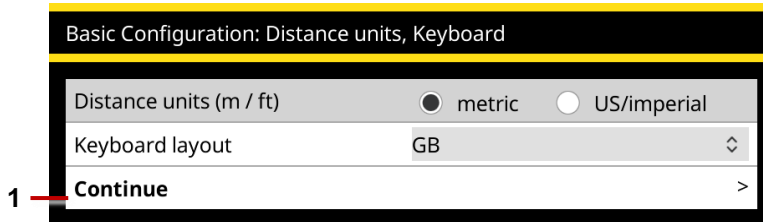
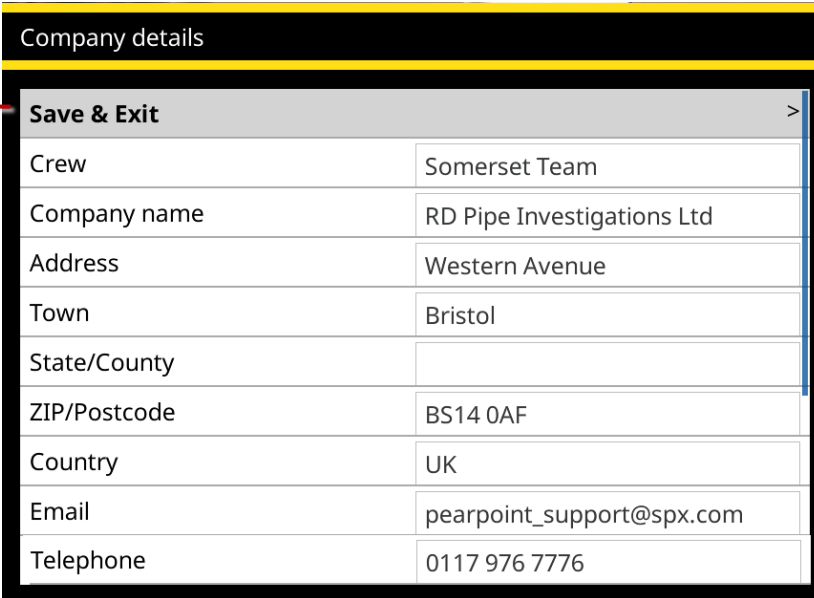

Fig. 5.4 Basic Configuration: Distance units and keyboard. 1 Continue menu item.

- 6 Enter your company details. Then select the **Save & Exit** menu item to quit the setup wizard.

The controller will use these details to personalize the title page of your survey reports. You can also import an image of your company logo, though you may prefer to do this later; see [page 92](#).



Company details

Save & Exit >	
Crew	Somerset Team
Company name	RD Pipe Investigations Ltd
Address	Western Avenue
Town	Bristol
State/County	
ZIP/Postcode	BS14 0AF
Country	UK
Email	pearpoint_support@spx.com
Telephone	0117 976 7776

Fig. 5.5 Basic Configuration: Company details. 1 Save & Exit menu item.

- 7 The controller now prompts you to select the reel type and calibrate the reel; continue to [page 68](#).

5.4 Calibrate the reel

Every time you power up the controller, you will need to calibrate the pushrod reel to ensure that camera distances are accurate. Briefly, after the setup wizard is complete:

1 Select the **reel type**.

In the Equipment settings menu, select the reel type currently attached to the controller. Then select the **Continue** menu item.

2 The controller now displays an advisory reminding you to rewind the pushrod fully onto the reel (coiler). Make sure the pushrod is layered evenly and correctly onto the reel *and* the end of the rod is level with the rod guide.

3 Press the **Calibrate** button to calibrate the reel.

After calibrating the reel, press the  **Back** button or Esc key to return to the controller home screen. You can now use the Settings menus to configure the system; continue to [page 69](#).

Note: *For definitions of calibration and zero distance, see [page 19](#).*

5.5 Configure the system settings





Use the Settings menus to configure the system before you start any pipeline surveys. For example, you can set the locale, date and time. You can specify where the date & time and camera distance are shown on the screen. You can also add your company details (these details are included in your survey reports).

From the main Settings menu, you can access:

- **Controller settings:** see [page 72](#).
- **Screen overlay settings:** see [page 74](#).
- **Equipment settings:** see [page 77](#).
- **Reporting settings:** see [page 78](#).
- **Network settings:** see [page 79](#).
- **Email settings:** see [page 84](#).
- **Dropbox settings:** see [page 85](#).
- **Maintenance settings:** see [page 88](#).
- **Company details:** see [page 91](#).

5.5.1 Using the Settings menu

Use the buttons and keyboard to navigate the menus. See Fig. 5.6 on [page 71](#).

- **Access the Settings menu:** Go to the home screen and press the  **Settings** button ([page 32](#)).
(If necessary, press the  **Back** button to go back to the home screen.)
- **Navigate the menus:** Do the following:
 - To browse items in a menu, use the **Up** and **Down** buttons or the   arrow keys.
 - To go back to the previous menu or screen, press the  **Back** button or the Esc key.
- **Select and edit a setting:** Press the **Select** button or the Enter key.

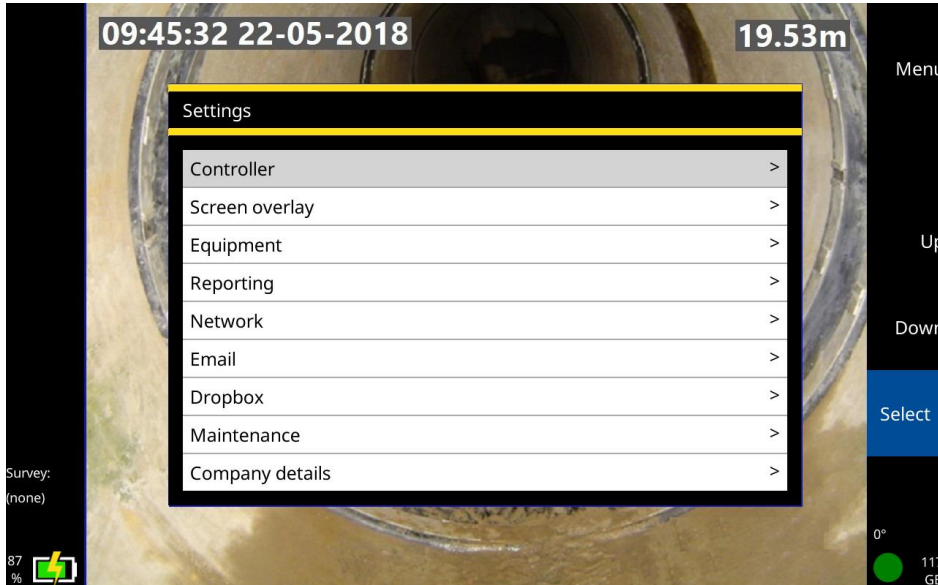

Fig. 5.6: Settings menu.

5.5.2 Controller settings

Use this menu to configure general controller settings.

- **Screen brightness:** You can adjust the screen brightness to suit the current lighting conditions. Select the setting. Then use the **Up** and **Down** buttons to adjust the brightness. Or you can use the \uparrow \downarrow arrow keys.

Note: *If the battery level is low on your controller, reduce the brightness to save battery power.*

- **Menu scrolling wraps around:** When enabled, this setting allows you to loop through all items in a menu using only the **Up** button, or only the **Down** button. For example, when you get to the bottom of menu, pressing the **Down** button will loop the cursor back to the top of the menu.
- **Language, distance units, keyboard layout:** You can set up the controller for your locale. For example, you can set the language for menus and buttons on the controller screen and you can show distance measurements in meters or feet (ie, metric or imperial).

If required, you can specify a different keyboard layout. Supported layouts include US, UK, German (QWERTZ) and French (AZERTY).

- **Date and time:** To ensure that your reports, videos and photos are correctly timestamped, you can set your time zone, your preferred date format (for example, DD/MM/YYYY or MM/DD/YYYY), and the current date and time.

Note: *The controller remembers the date, time and time zone, even if its battery is fully discharged. You will not need to re-enter these details after setting up the controller for the first time.*

- **Video source:** By default, the controller displays video input from the pushrod camera. But if required, you can connect an external camera to the controller and display video
 - **Camera:** This option displays video input from the pushrod camera.
 - **Auxiliary:** This option displays video input from an external camera. You must connect the external camera to the controller's RCA video jack ([page 29](#)).

5.5.3 Screen overlay settings

Use this menu to configure how the date & time and pushrod distance are shown on the screen and overlaid on video recordings and photos.

- **All hide/show:** This setting displays or hides the date & time and rod distance.
When this setting is enabled, this information is shown on the controller screen and on your survey videos and photos. If this setting is disabled, this information is hidden.
- **Date & time hide/show:** This setting displays or hides the date & time
- **Distance hide/show:** This setting displays or hides the pushrod distance ie, how far the rod is unwound from the reel.

- **Layout choice:** Choose where on the screen to display the date & time and pushrod distance. You can display this information at the top, bottom or center of the screen, or on the left or right.



All hidden



Top



Bottom



Middle



Left





Right

Fig. 5.7: Screen information layout options

- **Text background opacity:** By default, text overlaid on the screen has a semi-opaque background to make it easier to read. But you can adjust the opacity (0% to 100%) to suit video recording conditions. For example:

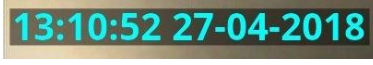
0% opacity: 

50% opacity: 

100% opacity: 

Note: *You cannot change the background opacity in a video after it has been recorded.*

- **Text color:** Choose the color of the overlaid text.
- **Video title page:** You can add a title page to the start of your survey videos.
 - **Title page duration:** Specify how long (in seconds) the title page is displayed when a video starts. This setting applies to all videos saved on your controller.
 - **Enable video title page:** This setting enables or disables the title page for all survey videos recorded *subsequently* on your controller.

If the title page is enabled, it is attached to all videos recorded subsequently. Conversely, videos recorded while the title page is disabled will not have a title page and *will not gain one if you subsequently enable the title page.*

You must *set up* a video title page before you enable it. To set up a title page, see [page 93](#).

- **Observation text overlay:** You can choose for observations to be overlaid as text on the recorded video.
 - **Show observation text on video:** Specify whether to show observations
 - **Observation text duration:** Specify how long (in seconds) each observation is displayed.
- **Text pages overlay:** You can choose for Text pages to be overlaid on the recorded video.
 - **Text page settings:** Edit text pages

5.5.4 Equipment settings

This menu is shown automatically after you calibrate the pushrod reel; see [page 100](#).

- **Reel type:** Select the reel type you are using from the dropdown list.

It is essential that you select the correct reel, for best video quality and accurate distance measurements. If you select the wrong reel, pushrod distance measurements will be inaccurate and your survey may be unusable.
- **Reel power off/on:** Use this setting to turn the reel camera off or on.

Note: *If the battery level is low on your controller, turn off the camera to save battery power.*

5.5.5 Reporting settings

The C540c can help you create reports which conform exactly to the reporting standard you chose when creating a survey.

- **Enforce mandatory fields:** When you select this option the C540c will report an error if you leave a mandatory field blank. (Correct the error so that you can continue.)
- **Validate format of entered data:** When you select this option, the C540c will report an error if you fill in a field in the incorrect format. (Correct the error so that you can continue.)

Select both options when you must create reports strictly complying with a given standard, Turn off one or both options when you would like the increased flexibility for entering freeform text.

5.5.6 Network settings

Use this screen to connect the controller to the internet over a WiFi network. You will need an internet connection to send survey reports by email or upload them to Dropbox.

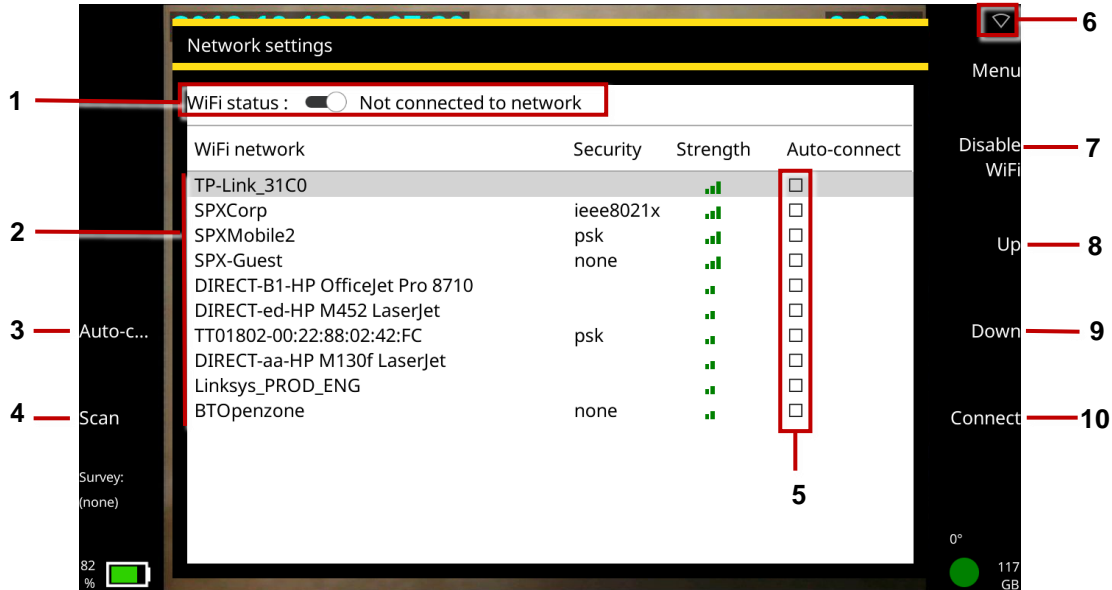

Fig. 5.8: Network settings. 1 WiFi status. 2 Network list. 3 Auto-Connect button. 4 Scan button. 5 Auto-Connect check boxes. 6 WiFi icon. 7 Enable/Disable WiFi button. 8 Up button. 9 Down button. 10 Connect button.

- WiFi status: Shows WiFi status, which may be:
 - Disabled
 - Not connected to network (but enabled)
 - Connected
- **WiFi icon:** Shows which WiFi network the controller is currently connected to. If the WiFi network has internet access, “**(online)**” is appended to the network name.

The connection status is also shown by icon (item 3 on [page 79](#)):



Not connected to a WiFi network



Connected to a WiFi network, but no internet connection





Connected to a WiFi network with an internet connection

- **Enable WiFi/Disable WiFi:** When you enabled WiFi, the controller automatically scans for available networks (*APs* or *access points*). For each network, you can see its name (or SSID), security protocol (if secure) and signal strength.

Note: *If your current location is not within range of a fixed WiFi network, you can enable a personal hotspot on your cell phone. This allows other devices, including the C540c controller, to share your phone’s data connection. (This method is also called data tethering.)*

Note: *If the battery level is low on your controller, disable WiFi to save battery power. When WiFi is enabled, a **Disable WiFi** button is shown on this screen.*

- **Network list:** Any available WiFi networks are listed on this screen. For each network, you can see its name (or SSID), security protocol (if secure) and signal strength.
- **Connect:** Use the Up/Down buttons or the   arrow keys to select the network you want. Then press the **Connect** button. Wait while the controller connects to the selected network. (While the controller is connected to a network, the Connect button is replaced by a **Disconnect** button.)

If you choose a secure network, the controller prompts you for the network password. The password is case-sensitive, and so be careful check whether Caps Lock is on, indicated by the  icon in the lower left corner of the screen. By default, password characters are obscured but you can click the **Show password** button to display the actual characters.



Fig. 5.9: Set password dialog. This dialog displays when you connect to a secure WiFi network for the first time. 1 Show Password button.

- **Auto-connect:** Use the $\uparrow\downarrow$ arrow keys to select a network. Then press the **Auto-connect** button to select the network's check box. In future sessions, the controller will automatically re-connect to this network whenever WiFi is enabled.

To disable auto-connecting, press the **Auto-connect** button again to clear the network's check box.

- **Scan:** The controller automatically scans for available networks each time you enable WiFi. But you can press the **Scan** button to manually refresh the network list.

5.5.7 Email settings

Use this screen to set up a connection to an email server. You will need to do this if you want to send survey reports by email. You will also need to set up a WiFi connection to the internet; see [page 79](#).

- **User Email:** Enter the email address for the account you want to use when sending emails from the controller. The controller will use this account to connect to the email server.
Note: *You will select the email recipient when you send a survey report.*
- **Password:** Enter the password for the account you will use to send emails from the controller.
- **Username:** If required, enter the SMTP Username for the account you want to use when sending emails from the controller.
Note: *Some email services, including Gmail, will use the SMTP Username attribute as the sender's address instead of the supplied User Email address.*
- **Server:** Enter (or select) the email server you want to use.
If the controller detects a recognized email account type (eg, Outlook or Gmail), it automatically sets the appropriate email server (smtp-mail.outlook.com or smtp.gmail.com).
- **Port:** If using an SMTP connection, you must enter the TCP port for email submission on your SMTP server. The default is port 587.
- **Requires secure connection (TLS):** By default, the controller always sends emails over a secure (encrypted) connection ie, over an SMTPS connection. But you can clear this check box if it is acceptable to send survey reports over an unencrypted connection

5.5.8 Dropbox Settings

Use this screen to set up a connection to a Dropbox account. You will need a Dropbox connection if you want to upload survey reports to the cloud.

Before you use this feature, you must have a Dropbox account and the controller must be connected to the internet.

To set up a Dropbox connection:

- 1 Select Connect to Dropbox from the Dropbox settings menu
- 2 Confirm that the controller has an internet connection; see [page 79](#).
- 3 From the Dropbox Settings menu, select **Connect to Dropbox**.

This will launch a conventional Dropbox Login screen sequence.

Instructions continue on next page.

- 4 In the **Dropbox authentication and authorization** screens, enter the email address and password for a valid Dropbox account using the keyboard **Tab** key to navigate from one box to the next.

Note: *We recommend that you do not use your personal Dropbox account. Instead, use a company account or a custom account specifically for storing survey reports.*

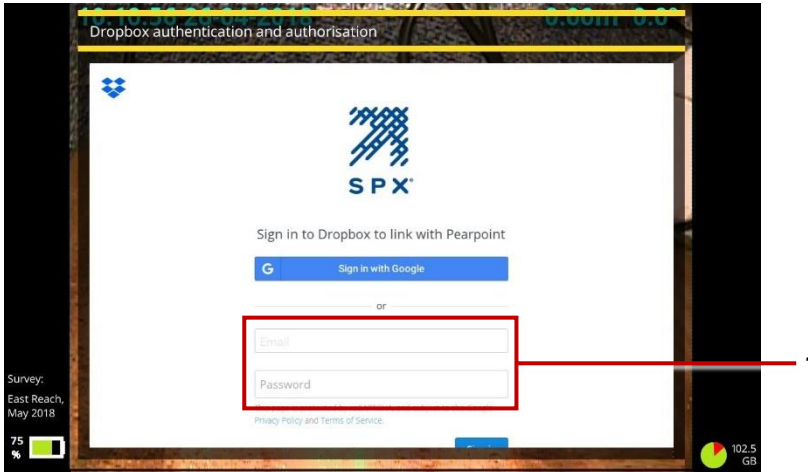

Fig. 5.10: Dropbox login screen. 1 Email address and password.

- 5 If prompted, follow the instructions on the reCAPTCHA verification screen.

Note: *reCAPTCHA is a Google spam prevention test designed to confirm that a computer user is human and not a bot.*

- 6 When prompted, allow CUES to create a subfolder inside your Dropbox folder tree; see [page 153](#) for details about the target subfolder.

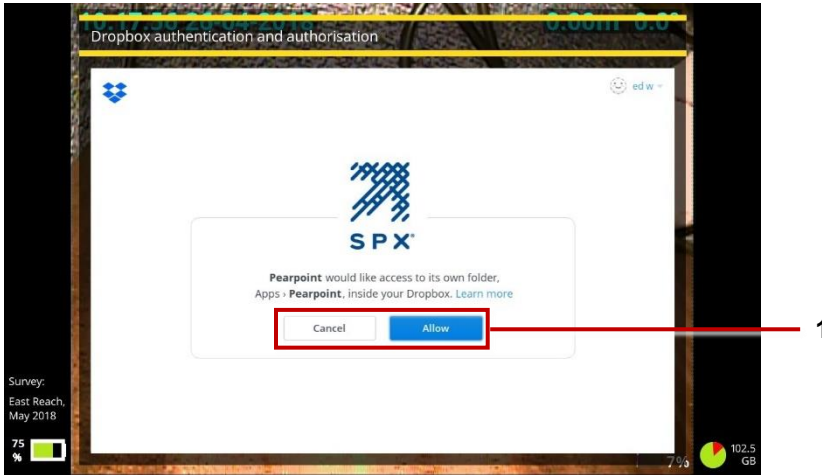

Fig. 5.11: CUES access request. 1 Cancel and Allow buttons.

To sign out of Dropbox: Select **Sign out** from the Dropbox settings menu.

5.5.9 Maintenance

Use this screen to set power management options, update the controller software, for diagnostic tasks, and reformat your USB memory stick to FAT32.

- **Power management:** Use these settings to reduce power consumption and prolong battery life. For each setting, you define an 'idle controller' timeout. This timeout refers to a period, in minutes, when there is no interaction with the controller keyboard or buttons.
 - **Dim screen after idle (minutes):** Screen brightness is a major drain on battery charge. This setting automatically dims the screen after a period of inactivity. Set a timeout (in minutes) for dimming the screen. If the controller keyboard or buttons are not used before the timeout expires, screen brightness is reduced to its lowest level.
 - **Shutdown after idle (minutes):** This setting automatically powers down the controller after a period of inactivity. Set a timeout (in minutes) for powering down the controller. If the controller keyboard or buttons are not used before the timeout expires, the controller powers down.
 - **Rod power off after idle (minutes):** The pushrod camera has a major effect on power consumption. This setting automatically powers down the camera after a period of inactivity. Set a timeout (in minutes) for powering off the camera. If you do not use the controller keyboard or buttons before the timeout expires, the camera powers down.
- **Software update:** Use this setting to install software updates from a USB memory stick. For details, see [page 177](#).

- **Software versions:** Lists the installed versions of various firmware and software components. This information may be needed by CUES support staff for diagnostic purposes.
- **System info:** Lists Serial number(s), IP addresses and MAC addresses.
- **Application debug log:** Use this setting to view and export log files. These logs are used by CUES support staff to diagnose controller issues.
- **Diagnostics:** This screen displays status data for various system components. This data can be used by CUES support staff to diagnose controller issues.
- **Format USB disk:** Use this setting to reformat your USB memory stick to FAT32. .
The controller does not support USB memory sticks that have an NTFS file system. If your USB memory stick uses NTFS, you will need to reformat it before you can export your surveys to the memory stick.
Caution: *Reformatting your USB memory stick will erase any files currently saved on the stick.*
- **Factory reset:** Resets your controller to its factory settings.
Caution: *Resetting the controller will erase all your surveys, also system settings, personal preferences and your company details.*
- **Feature enable menu:** Use this menu to install feature-enabling certificates such as WinCan. To add the ability to create WinCan-compliant survey reports follow these steps:
 - 1 From the home screen, press the *Create a survey* key, see [page 126](#).

- 2 In the *Create survey* menu, navigate to *Format* and select WinCan.
- 3 Choose your country, language and standard as appropriate
- 4 Navigate to *Continue*, and press Select. You will be shown a pop-up containing information specific to your controller.

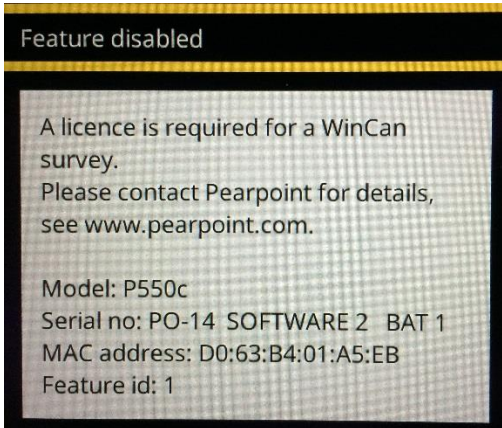

Fig. 5.12: Feature disabled pop-up, containing the information required to enable your controller.

- 5 Email the Model, Serial no, MAC address and Feature id information to your local CUES representative. You can use the *Contact Us* form on the www.cuesinc.com website for this purpose.

- 6 You will shortly be emailed a [cert.asc](#) file. Copy this to a USB stick, which should be put into one of the USB ports on the P550 controller.
- 7 Return to the Feature enable menu, navigate to *Install feature enable certificate* and press *Select*.
- 8 Navigate to the folder on the USB stick containing the [cert.asc](#) file, highlight the [cert.asc](#) file and press *Select*.

This will result in a message saying that the feature has been installed successfully, and the [cert.asc](#) file should now be listed in *Enabled features*. If this is not the case, please contact your local CUES representative.

5.5.10 Company details

Use this screen to enter your company details and, if required, your company logo. The controller will use these details to personalize the title page of your survey videos and reports.

After entering your company's details, you will not need to re-enter them unless you perform a factory reset; see [page 176](#).

To import a company logo, see [page 92](#).

5.6 Import a company logo

You can import your company logo to personalize the controller splash screen (shown briefly on startup) and the title page of exported survey reports.

Follow these steps:

- 1 Copy the logo image (PNG or JPG only) to a USB memory stick and attach the stick to the controller. You can use any of the controller's USB ports.

Note: *The image file must be smaller than 2MB.*

- 2 In the Home screen, press the  **Settings** button (item 6 on [page 32](#)).
- 3 Choose Settings > Company Details.
- 4 Scroll to the bottom of the Company Details menu and choose **Select company logo**.
 - a. In the Image Import screen, select the logo.



Use the   arrow keys and the Esc and Enter keys to navigate folders on the USB memory stick and select the file you want.
 - b. Press Enter or the **OK** button to import the logo.
- 5 Back in the Company Details menu, the **Company logo** is automatically set to Active.



Fig. 5.13: Example title page for exported survey report (Microsoft Word format only). 1 Your company logo. 2 Your company name, address and phone number

5.7 Set up a video title page

(This task is optional)

You can set up a title page for all your survey videos. If the video title page is enabled, it is attached to all videos recorded subsequently on the controller. The title page displays at the start of the videos.

The title page can include company details, including a logo or image, and survey details. Note that the survey details are taken from the *header* that you supply when you create a survey. The header refers to the basic survey details recorded on an MSCC standard coding form (date, location, surveyor and so on).

You must set up the title page *before* you record any videos. If you record a survey video before setting up a title page, the video will not gain a title page if you subsequently set up a title page.

Instructions for designing a title page are on [page 95](#).

5.7.1 Can I set a custom title page?

Yes. If you design the title page to include *survey text*, these text elements always reflect header details for the current survey. For example, although the same title page is used for all survey videos, you can design the title page to always show the date and location of the current survey.

If you want a completely different title page for a particular survey video, you can temporarily customize the current title page, record a new survey video, and then undo the customizations and restore the title page to its previous state.

5.7.2 Design the video title page

Follow these steps:

- 1 Set up a new survey (see [page 126](#)) or open a survey (see [page 133](#)).

You can only edit the title page when a survey is open.

- 2 In the *Edit Survey* screen, press the  **Title page** button.

The current title page now appears (if set up) and the buttons change to allow editing of the title page

- 3 **Add text and graphic items.** Use the following buttons to add text and graphics to the title page:

- **Add company details:** Adds an item of company information, for example, the company name or phone number. (You cannot change the company name, phone number, etc., from this menu, only decide whether or not they are displayed. To make changes, select Settings then Company details from the home menu.)
- **Add survey details:** Adds a survey header detail, for example, the survey date, location or remarks. When you record a video, the title page is populated with header details from the *current survey*. In effect, adding survey text allows you to customize the title page for each video. (To change the contents of the survey header, press the Edit survey header  button.)
- **Add text:** Adds a general text caption. This will appear in the title page for all your videos.
- **Add graphic:** Press this button to import an image file from a USB memory stick.

(First, you need to save the image to a USB memory stick and insert the memory stick into a controller USB port. Use the $\uparrow\downarrow$ arrow keys and Enter keys to select the image you want.)

When you add a text element or graphic, it displays in the center of the screen. You can now reposition the element. You can also resize graphics.

- 4 **Position and edit each item.** Set up the items on your page:
 - a. Press the **Select item** button repeatedly until the item you want is highlighted in red.
 - b. Use the $\leftarrow\rightarrow\uparrow\downarrow$ arrow keys on the keyboard to position the item on the screen.
 - c. *Graphics only:* Press the **Enlarge** or **Shrink** buttons to resize the item.
 - d. *Text only:* Press Enter on the keyboard to edit the text. Press Enter again to save the changes.

If you need to remove an item, press the **Delete** button.

- 5 Press the **Settings** button to enable or disable the video title page, and to set the duration (in seconds) for which the title page is displayed.
- 6 The title page design is saved automatically. Press Esc or the  **Back** button to quit the title page and return to the home page.
- 7 Now enable the video title page; see the next section.

5.7.3 Enable the video title page

After designing the title page, you must enable it to automatically add it to all survey videos recorded subsequently on the controller:

- 1 Make sure that you have designed the title page; see [page 95](#).
- 2 In the Home screen, press the  **Settings** button (item 6 on [page 32](#)).
- 3 Choose Settings > Screen Overlay > Video title page.
- 4 Set the **Title page duration**, in seconds. This controls how long the title page is displayed at the start of a video.
- 5 Set the **Enable video title page** slider to On to enable the title page.

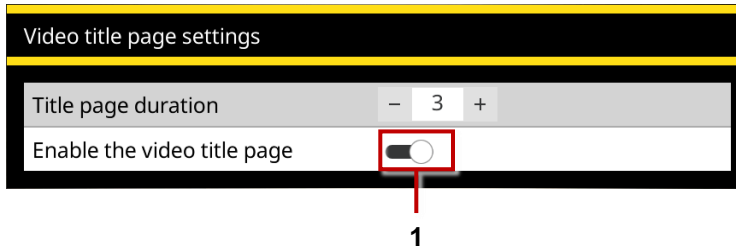

Fig. 5.14 Video Title Page Settings menu. 1 Enable video title page slider (shown in the On position).

Note: *The setting only applies to videos recorded subsequently. Any existing videos saved on the controller are unaffected. In particular, if an existing video does not have a title page, it will not gain a title page if you subsequently enable the video title page.*



6 The change is saved automatically. Press Esc or the  **Back** button to quit the menu.

Alternatively, set the **Enable video title page** slider to Off to disable the title page in all videos that you record subsequently.

6 Operating the system

This section describes how to operate the C540c system.

6.1 Before you begin

-  *Assess your deployment and safety requirements before you begin. Different environments may pose risks and challenges that you may be unaccustomed to.*
-  *Check that no hazardous gases or vapors are present. Do **not** use the C540c system in potentially explosive environments.*
-  *Seek assistance if required and always use correct heavy-lifting practices.*

6.2 Calibrate the reel

Every time the controller is powered on and connected to a reel, it prompts you to select the reel type and calibrate the reel. You must also calibrate the new reel if you change reels (connect a different reel to the controller). The reel must be correctly calibrated to ensure that camera distances are accurate.

Note: For definitions of calibration and zero distance, see [page 19](#).

Follow these steps:

- 1 Rewind the pushrod completely.
Make sure the pushrod is layered evenly and correctly onto the reel *and* the end of the rod is level with the rod guide.
- 2 Power on the controller.
- 3 In the Equipment settings menu, select the **Reel type** you are using from the dropdown list and ensure Reel power is on. Then press Select

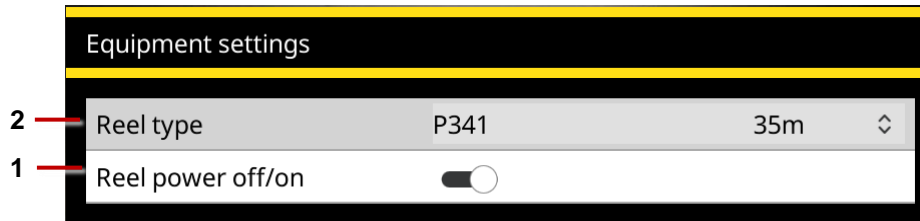

Fig. 6.1 Equipment settings menu. 1 Reel type. 2 Reel power off/on (shown in the On position).

Caution! *It is essential that you select the correct reel for best video quality and accurate distance measurements. If you select the wrong reel, pushrod distance measurements will not be accurate and your survey may be unusable.*

- 5 The controller now displays an advisory reminding you to fully rewind the pushrod.
If the rod *is* fully coiled on the reel, press the **Calibrate** button.
If the rod is *not* fully coiled on the reel, rewind the rod completely. Then press **Calibrate**.

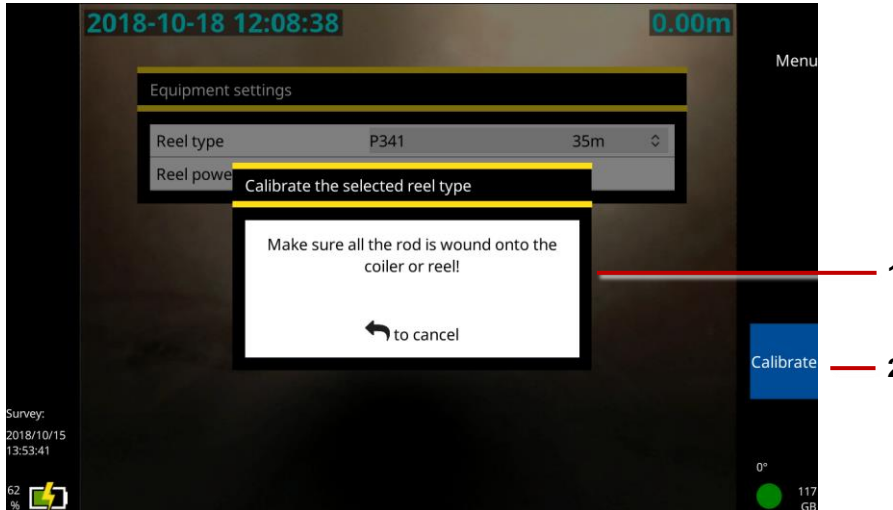

Fig. 6.2 Calibration reminder. 1 Advisory to rewind the rod. 2 Calibrate button.

6.3 Deploy the camera

Unwind the pushrod some distance so you can deploy the camera down into a manhole before starting the pipe survey. Follow these steps:

- 1 Slowly release the brake and rotate the reel to unwind the pushrod.

Caution: *Pushrods can self-propel and cause injury to the operator. We recommend that you adjust the brake slowly to prevent the reel unwinding too quickly. You can adjust the brake lever position by pulling it out and turning.*

- 2 When a sufficient length of pushrod is free, insert the camera into the pipe or manhole.
- 3 Push the pushrod by hand until the camera is in position to start the survey. Rotate the reel if you need more length.
- 4 Zero the camera distance; see [page 103](#).

6.4 Zero the camera distance

Your survey needs to accurately record the distance of the camera from the starting manhole. This ensures that pipe defects can be accurately located. However, in most cases you will need to unwind the pushrod some distance so you can deploy the camera down into a manhole before starting the survey.

To ensure accurate camera distances are recorded in your survey videos and observations, you need to zero the camera distance when the camera is in position (typically in the center of a manhole) before you start the survey.

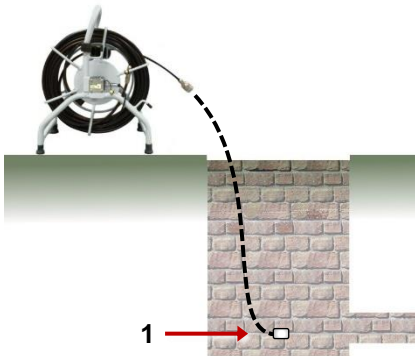

Fig. 6.3: Zeroing the camera position. 1 Zero the camera position when the camera is here.

Note: This task is also called ‘zero distance’ and ‘zeroing the rod counter’. Do not confuse this task with zero calibration of the reel. See the definitions in [page 19](#).

Follow these steps:

- 1 Get the camera in the survey start position; see [page 103](#).
- 2 Press the **0.00** **Set distance** button or **0.00** *panel button* and reset the distance to 0.00.
- 3 Make sure the on-screen distance counter shows **0.0ft** or **0.00m**; see item 2 on [page 32](#).

6.5 Record a video

Recording a video is simple. Before you start recording, you just need to decide whether to add the video to a new or existing survey.

With the C540c system, all videos must be attached to a survey. You can set up a new survey when you launch a video recording ([pages 108 and 109](#)), or you can open an existing survey and add new video recordings to it ([page 111](#)).

6.5.1 Video format and size

The C540c system saves survey videos as MP4 files, encoded in H.264 for video and MP3 for audio.

The controller limits individual MP4 files to 4GB, corresponding to a survey video of approximately two hours. If a video recording is underway when you reach this file size limit, the controller automatically stops the recording. If your survey is likely to exceed two hours, you will need to record two separate videos.

Note: *This size limit allows you to export survey videos to a USB memory stick. The memory sticks supported by the controller use the FAT32 file system. Individual files on FAT32 drives cannot exceed 4GB in size.*

6.5.2 About the panel buttons

Use the panel buttons to record, play, pause and stop a video. You can also capture still images ie, observation photos. The panel buttons are located below the controller screen; see [page 31](#).

 Record/Pause

 Play/Pause



 Stop

 Camera

 Set Camera Distance

6.5.3 On-screen recording indicators

While a recording is in progress, recording status indicators are shown in the lower-right screen:

- A red dot  on the screen indicates that recording has started. Also the red Recording LED will light. See [page 32](#).
- The mic symbol indicates whether audio recording is on  or muted .
- There are timers for the current recording plus the *estimated* total recording time available, based on the current level of free disk space.

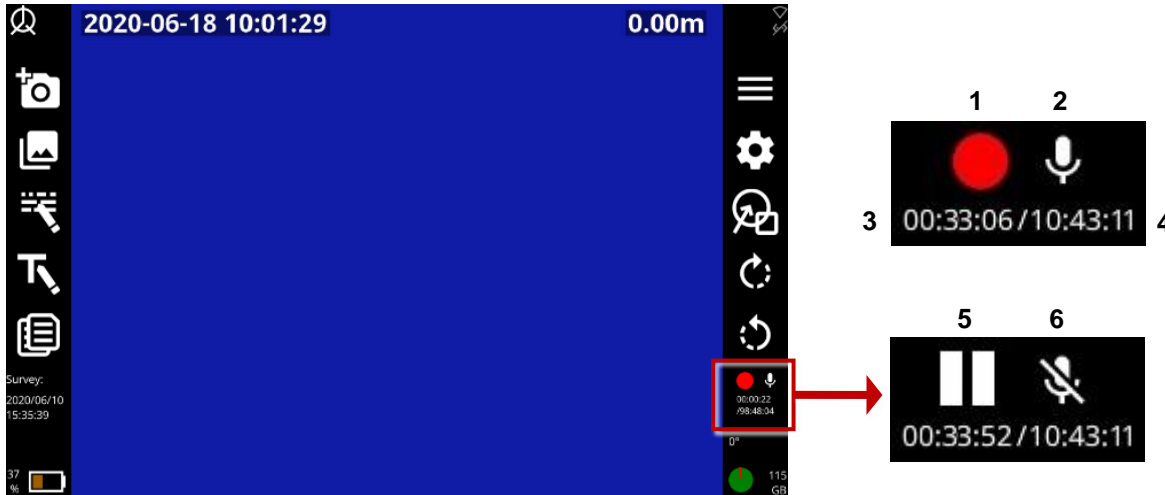





Fig. 6.4 Recording status indicators. 1 Recording in progress. 2 Audio recording on. 3 Timer for current recording. 4 Total recording time available (estimated). 5 Recording paused. 6 Audio recording muted.

6.5.4 Quickly record a new video

(Available for basic surveys only) This is the fastest way to record a new video:

- 1 *(Optional)* Connect a headset to record an audio commentary.
- 2 Press the  panel button twice to automatically set up a basic survey and start recording.
- 3 Now carry out the video inspection. Use the controller tools to:
 - Pause the recording, rotate the camera, use a Sonde, mute an audio commentary, and highlight pipe defects. See [page 112](#).
 - Take a photo. See [page 113](#).
 - Add an observation. See [page 156](#).
 - Add a Text page. See [page 114](#).
- 4 Press the  panel button or  **Stop** button to stop the recording.

Note: *The survey name defaults to the current date and time. To rename the survey, see [page 135](#).*

6.5.5 Set up a new survey and record a new video

Follow these steps:

1 (Optional) Connect a headset to record an audio commentary.

2 Press the  panel button.

3 Before the video starts recording, you must specify the following details:

Name: The survey name defaults to the current date and time, but you can set a custom name. You can also rename the survey later; see [page 135](#).

Format: Choose one of the following:





- **Basic survey:** You do not need to specify any details at this point. If required, you can later edit the survey header to specify the operator (the person carrying out the survey), job number, date and time, location of the survey, plus any remarks. See [page 136](#).
- **Structured survey (WRc):** You must choose the survey standard. For example, you can choose MSCC5 Sewerage, MSCC5 Domestic or MSCC5 Highways. For a list of currently supported standards, see [page 165](#) and the pages that follow.
- **Structured survey:** Choose between French and Spanish versions of EN13508.

4 Select the **Continue** menu item.

5 *(Applies to Structured surveys only)* Fill out the details required for your chosen survey standard.

- The current field is highlighted in gray.
- Mandatory fields are highlighted in yellow.



Tip: Press the **Super tab** button to quickly tab through the mandatory fields only. You can fill in the other fields later; see [page 136](#).

- Press the     arrow keys to move through *all* the header fields.
- Fields with  buttons have a drop-down menu. For drop-down menu shortcuts, see [page 166](#).
- Press Save to save the form.

6 *(Applies to Structured surveys only)* Press the  panel button to start recording.





7 Now carry out the video inspection. Use the controller tools to:

- Pause the recording, rotate the camera, use a Sonde, mute an audio commentary, and highlight pipe defects. See [page 112](#).
- Take a photo. See [page 113](#).
- Add an observation. See [page 156](#).
- Add a Text page. See [page 114](#).

8 Press the  panel button or  **Stop** button, and press Yes to confirm, to stop the recording.

6.5.6 Record a further video for the survey currently open

You can record multiple videos for a single survey. Follow these steps:







- 1 (Optional) Connect a headset to record an audio commentary.
- 2 Open the survey that you want to update; see [page 133](#).
- 3 Press the  *panel button* once.
- 4 According to the survey standard chosen, a pop-up menu Multiple video recordings may be displayed. Press Yes if you want to add a VVR condition code to the observations, otherwise press Esc or the  **Back** button to continue without recording the VVR code.
- 5 Now carry out the video inspection. Use the controller tools to:
 - Pause the recording, rotate the camera, use a Sonde, mute an audio commentary, and highlight pipe defects. See [page 112](#).
 - Take a photo. See [page 113](#).
 - Add an observation. See [page 156](#).
 - Add a Text page. See [page 114](#).
- 6 Press the  *panel button* or  **Stop** button to stop the recording.

6.6 Video tools

The controller provides various tools to augment or enhance your survey videos.



6.6.1 Pause, resume and stop recording

You can pause and resume a video recording at any time. For example, you may want to pause the video while you highlight a pipe defect with an on-screen arrow or circle.

- **On-screen indicators:** A red dot  and video counter are shown on the screen when the controller is recording a video.
- **Pause a video:** While a video is recording, press the  panel button to pause the recording.
Note: You cannot press the  panel button to pause or resume a live recording.
- **Resume a paused video:** While a video is paused, press the  panel button again to resume recording.
- **Stop a video:** While a video is recording or paused, press the  panel button or  Stop button.

6.6.2 Rotate the video feed

You can rotate the video feed on the screen at any time.

Press the  or  buttons to rotate the video clockwise or anticlockwise. The angle of rotation in degrees is shown bottom left of the screen. Note that the camera itself is not physically rotated.

6.6.3 Take a photo

You can take photos (ie, capture screenshots) at any time when a survey is open. For example, you can take photos while recording or playing a video. You can also take photos directly. Any photos taken while a survey is open are listed in the survey report when you export the survey.

A photo is saved automatically as a .jpeg image each time you add an *observation*. The photo shows exactly what is on the screen at the time of the observation. To review your photos later, you open the associated observations.

To take photos directly, see [page 123](#).

To add an observation while recording or playing back a video, see [page 154](#).

For details about survey reports, see [page 163](#).

6.6.4 Add Text pages

While recording a survey video you can overlay text to the screen using the *Text pages* feature. Users may enhance simple video surveys by adding relevant information e.g Location; reference/ node points. The *Text pages* are displayed over the video footage when selected either before or during the recording.

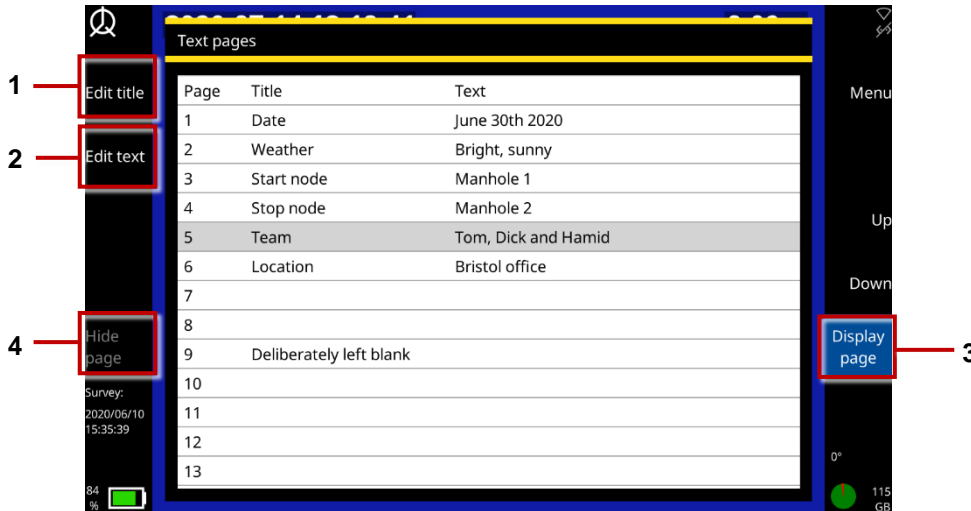

Fig. 6.5: Editing and adding Text pages to a video recording. 1 Edit title. 2 Edit text. 3 Display page. 4 Hide page.

Follow these steps:

1 Press the  **Text pages** button.

2 Choose from:

- Edit title: Add a reference name for the text page.
- Edit text: Add content to the text page that you want displayed in your video. Use the Home, End and arrow keys to position the cursor.
- Press Spacebar to edit the selected text page from the Menu page.

3 Press **Display page** to add the text to your video. Press **Hide page** to remove it. The displayed page number is indicated at the bottom/ centre of the screen.

4 Start recording a survey video; see [page 105](#).

5 To change the on screen text page choose from:

- Press keys 1 through 9 to select an individual page.
- Use Page Up/ page down **icons** keys to cycle through all available text pages (1 to 30).
- Press Home key to return to page 1.
- Press the End key to hide the page.

Note: *You cannot add text pages after recording the video.*

6.6.5 Add overlay text and shapes to video segments

While recording a survey video, you can add text and shapes to highlight pipe defects. These *overlays* are displayed over the video footage.





Fig. 6.6: Adding overlay items to a video recording. 1 Overlay text and shapes. Buttons: 2 Add shape. 3 Add text. 4 Add graphic. 5 Select item. 6 Delete item. 7 Enlarge item. 8 Shrink. 9 Enable overlay / Disable overlay.

You can precisely resize and position the overlays and you can control how long (in seconds) they are displayed on the screen.

For example, you may want to add a 10-second overlay to your video, comprising an arrow and explanatory caption, to highlight a crack or debris.

Note: *You cannot add overlays after recording the video. For example, you cannot add a new arrow and text caption while playing back a survey video. (Of course, you can export the .mp4 video and overlay graphics and captions using third party video editing software.)*

Follow these steps:

- 1 Start recording a survey video; see [page 105](#).
- 2 Press the  *panel button* to pause the recording when you observe a pipe defect or another feature that you want to highlight.
- 3 With the video paused, press the  **Overlay graphics** button.
- 4 **Add overlay items.** Choose from:
 - **Shapes:** Use squares, circles and arrows to highlight features visible on the screen.
 - **Text:** Add explanatory captions.
 - **Graphics:** Add any custom images, such as a hazard symbol. (First, you need to save the image to a USB memory stick and insert the memory stick into a controller USB port. Use the ↑↓ arrow keys and the Enter key to select the image you want.)

- 5 **Position and edit each item.** While video recording is paused:
 - a. Press the **Select item** button repeatedly until the item you want is highlighted in **red**.
 - b. Use the ← → ↑ ↓ arrow keys on the keyboard to position the item on the screen.
 - c. Shapes and graphics: Press the **Enlarge** or **Shrink** buttons to resize the item.
 - d. Text: Press Enter on the keyboard to edit the caption. Press Enter again to save the changes. If you need to remove an item, press the **Delete** button.
- 6 **Enable the overlay.** Press the **Enable overlay** button.

Do not omit this step. You must enable overlays to make them visible in your video recording! They will stay visible until you disable overlays in step 8.
- 7 **Resume recording** for several seconds *but do not move the camera!*

For example, to display the overlays for 10 seconds, resume recording for 10 seconds. The overlay items will remain visible during this segment of the video. You could also record an audio commentary over this segment, for example, to explain the highlighted pipe defect.
- 8 **Disable the overlay.** Press the **Disable overlay** button to remove the overlay items from the next video segment. (You do not need to pause the recording to do this.).
- 9 Continue the pipe survey.

If you detect further pipe defects that you want to highlight, repeat steps 2 through 8.

6.6.6 Record an audio commentary

You can add an audio commentary while recording a survey video.

- 1 Attach a mic or headset to the covered audio socket on the front of the controller (item 3 on [page 25](#)).
- 2 Start recording a survey video.

Audio recording is enabled by default, so you can immediately start speaking into the microphone.

- 3 *(Optional)* To mute the microphone, press  *panel button*. To unmute and resume audio recording, press the button again.

To listen to an audio commentary, see [page 120](#).

Note: *You cannot add or edit the audio commentary after recording the video. For example, you cannot add a new audio commentary while playing back a survey video. (Of course, you can export the .mp4 survey video and edit the audio track using third party video editing software.)*

6.6.7 Listen to an audio commentary

When playing back an inspection, you can listen to the audio commentary on a headset or on loudspeakers attached to the controller.

- 1 Attach a headset or speakers to the covered audio socket on the front of the controller (item 3 on [page 25](#)).

You must use speakers with a 3.5mm audio jack; you cannot connect USB or Bluetooth speakers to the controller.

- 2 Play the survey video; see [page 121](#).
- 3 If required, adjust the playback volume; see [page 122](#).

6.6.8 Use a Sonde

Reserved for future use. In future releases, this  panel button will operate a Sonde independently of the camera.





6.7 Replay a video

To replay a video, you must first open the survey that the video is attached to. While the video is playing, you can stop, pause, forward and rewind, and add new observations.



Fig. 6.7: Video playback screen. 1 Next observation button. 2 New observation button. 3a, 3b Rewind and Fast Forward buttons. 4 Stop button. 5a Volume Control button. 5b Volume level. Use the keyboard arrow keys to adjust the volume.

Follow these steps:

- 1 Open a survey; see [page 133](#).
- 2 Press the  *panel button*; see [page 106](#).
- 3 Available videos are listed in the *Video browser* screen.
- 4 Use the  arrow keys to select the video you want. Then press Enter.
- 5 While the video playing, the *playback* buttons are available.
The *playback* buttons allow you to: stop and pause the video; view and add observations; and fast forward or rewind the video.
- 6 To stop playing the video, press the  *panel button* or  **Stop** button.
Or press the  **Back** button to quit the video and return directly to the *Edit Survey* screen.

6.7.1 Fast forward and rewind

Press the **Fast forward** or **Rewind** buttons. Each press increases the speed through x2 to x16.

6.7.2 Adjust the playback volume

Press the **Volume control** button. Then use the  arrow keys to lower or raise the volume.

6.8 Take a photo directly

Typically, you take photos (that is, capture still images) while recording or playing back a video. But you can also take photos directly, without recording or playing a video. For example, a survey video may be unnecessary because you only want to photograph a specific pipe defect.

Follow these steps:

- 1 Open an existing survey ([page 133](#)). Or create a new one ([page 128](#)).
Photos are saved as observations, and each observation must be associated with a survey.
- 2 Deploy the camera into the pipeline.
The camera feed is displayed on the controller screen. You can rotate the camera feed if necessary; see [page 113](#).
- 3 (*Optional*) When the camera is in position and the image you want is displayed on the controller screen, you can add overlay text and shapes to the image.
For example, you can add an arrow and explanatory caption. For instructions, see [page 114](#).

- 4 Press the  panel button (page 31), or the New observation button to take the photo.

The photo shows exactly what is on the screen at the time, including any overlay text or shapes, camera rotation, date & time and camera distance.



Fig. 6.8: Example screen display before the photo is taken.

- 5 The *New Observation* screen displays, showing the new photo.
- 6 Fill in the fields required by the survey standard (see [page 165](#)). Then press the **Save** button to save the observation details and photo.

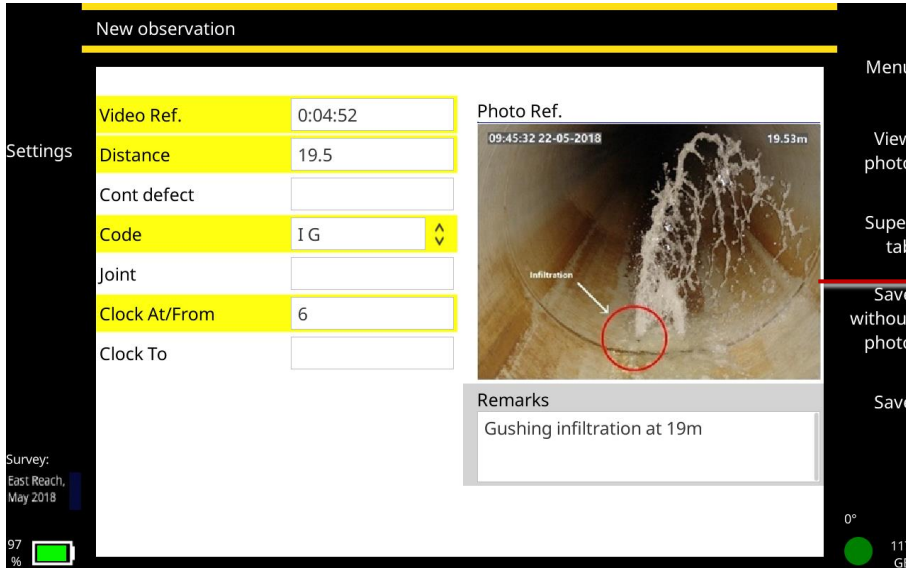



Fig. 6.9: New Observation screen showing new photo (1).

6.9 Turn off the camera

If the battery level is low on your controller, you can turn off the camera to save battery power:

- 1 In the Home screen, press the  **Settings** button (item 6 on [page 32](#)).
- 2 Choose Settings > Equipment.
- 3 Set the **Reel power off/on** slider to Off.

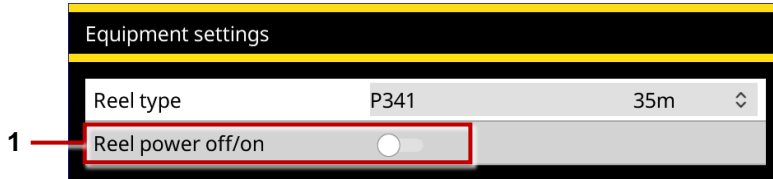

Fig. 6.10: Equipment settings. 1 Reel power off/on slider (shown in the Off position).

6.10 Retrieve the camera



Warning! *Foul water systems can be a source of biological hazards. Maintain high sanitary standards at all times. Clean the system after each inspection with a cloth soaked in disinfectant. Always wear appropriate protection when conducting an inspection and when handling the C540.*

After you complete the survey, wind the reel to retrieve the camera from the pipe.

4 Release the brake.

5 Carefully layer the pushrod onto the reel by a combination of rotating the reel and pushing the pushrod onto the reel. *Do not simply rotate the reel!*

Caution: *Layer the rod onto the reel evenly. If you fail to do so, displayed camera distances may be inaccurate when you next conduct a survey.*

6 Clean the pushrod and camera:

- Clean the camera with water and disinfectant.
- Clean the pushrod with a cloth moistened with disinfectant.

7 Surveys

This section describes how to create and manage pipe surveys (also called *pipe inspections*). The controller generates a survey *report* when you export the survey; see [page 137](#).

You can create *basic* or *structured* surveys. For structured surveys, the C540c controller supports WRc's MSCC 3 through 5 survey standards (see [page 169](#)) and French and Spanish EN13508 standards.

7.1 Create a new survey

Follow these steps:

- 1 In the home screen ([page 32](#)), press the  **Create survey** button.
- 2 In the *Create survey* dialog, set the survey details:

Name: The survey name defaults to the current date and time, but you can set a custom name.

Format: Choose one of the following:

- **Basic survey:** You do not need to specify any details at this point. If required, you can later edit the survey header to specify the operator (the person carrying out the survey), job number, date and time, location of the survey, plus any remarks. See [page 136](#).
- **Structured survey (WRc):** You must choose the survey standard. For example, you can choose MSCC5 Sewerage, MSCC5 Domestic or MSCC5 Highways. For a list of currently supported standards, see [page 165](#).

- **Structured survey:** Choose between French and Spanish versions of EN13508.
- 3 Select the **Continue** menu item.
- 4 (*Applies to Structured surveys only*) Now edit the survey header. For MSCC surveys, the header refers to the details recorded on an MSCC standard coding form (date, location, surveyor and so on). In the *Header* screen:
 - a. (*Optional*) Press the **Edit survey name** button and enter a descriptive name.
 - b. Fill in the fields required by the survey standard.
 - The current field is highlighted in gray.
 - Mandatory fields are highlighted in yellow. Press the **Super tab** button or Tab key to tab through the mandatory fields only.
 - Press the ←→↑↓ arrow keys to move through *all* the header fields.
 - Fields with ↓ buttons have a drop-down menu. For drop-down menu shortcuts, see [page 166](#).

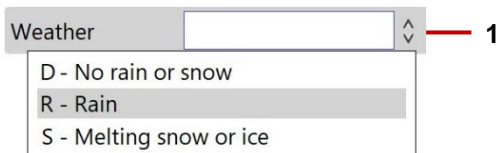

Fig. 7.1: Field with example drop-down menu. 1 Drop-down menu indicator.

- 5 (*Applies to Structured surveys only*) Press the **Save** button to save the survey header details.

The *Edit Survey* screen displays ([page 129](#)). You can now set up a video title page ([page 93](#)) or start a recording a video ([page 105](#)).

7.2 Edit survey screen

Use the *Edit survey* screen to edit the video title page, edit the survey header details, add or manage survey observations, and add or manage text pages.



Fig. 7.2: Edit survey screen. 1 New observation button. 2 List observations button. 3 Edit survey header button. 4 Title page button. 5 Text pages button. 6 Overlay graphics button (for observations). 7 Roll camera buttons.

7.3 Manage existing surveys

Use the *Existing Surveys* screen to manage your existing surveys.

The screenshot shows the 'Existing surveys' screen with a table of survey data. The table has columns for ID, Title, Survey type, Date, and time. The data is sorted by date in descending order. The screen includes a search bar at the top, a list of actions on the left, and a menu on the right. A status bar at the bottom shows battery level (75%) and storage (102.5 GB).

ID	Title	Survey type	Date	&	time
14	East Reach, May 2018	MSCC3	2018-05-08		09:36
13	High Street, May 2018	MSCC5 Domestic Manhole...	2018-05-08		09:22
12	Dalston Road, May 2018	MSCC5 Highways Drain/S...	2018-05-08		09:05
11	Priory Way E, May 2018	MSCC5 Sewerage Manhol...	2018-05-08		09:04
10	Priory Way N, May 2018	MSCC5 Sewerage Drain/S...	2018-05-08		09:02
9	Haydon Lane, May 2018	MSCC5 Domestic Drain/Se...	2018-05-08		08:48
8	Silver Street, May 2018	MSCC4 Highways Drain/S...	2018-05-04		16:26
7	This is My New Survey Na...	MSCC4 Sewerage Manhol...	2018-05-04		16:25
6	Vine Court S, May 2018	MSCC4 Sewerage Drain/S...	2018-05-04		16:21
5	Vine Court N, May 2018	MSCC4 Domestic Drain/Se...	2018-05-04		16:01
4	Western Avenue, May 2018	MSCC5 Highways Drain/S...	2018-05-04		15:47
2	Trull Road, May 2018	MSCC5 Domestic Drain/Se...	2018-05-02		16:13

Callouts in the image:

- 1: Select multiple
- 2: Delete selected
- 3: Export selected
- 4: Sort by title
- 4: Sort by date
- 5: Search

Fig. 7.3: Existing surveys screen. 1 Select Multiple button. 2 Delete Selected button. 3 Export Selected button. 4 Sort buttons (by title and date). 5 Search button.

7.3.1 Open a survey

In the C540c system, a survey must be open, or *active*, before you can record a video or take observation photos. Follow these steps:

- 1 In the home screen, press the  **Existing surveys** button
- 2 In the *Existing Surveys* screen, use the $\uparrow\downarrow$ arrow keys to select the survey you want.
- 3 Press the **Open** button.

The *Edit Survey* screen displays; see [page 131](#).

7.3.2 Search for a survey

You can quickly search for surveys by ID, title or survey type. Follow these steps:

- 1 In the home screen, press the  **Existing surveys** button.
- 2 In the *Existing Surveys* screen, press the **Search** button.
- 3 In the Search field, type any numbers or words (or partial words) that appear in a survey's ID, title or survey type.

The screen updates as you type to list the surveys that match your search term. For example, type 'MSCC5' to search for all types of MSCC5 survey.

To clear the search and display all existing surveys, press the **Search** button again.

7.3.3 Sort surveys by title or date

You can sort surveys by title or date created. Follow these steps:

- 1 In the home screen, press the  **Existing surveys** button.
- 2 In the *Existing Surveys* screen, press the **Sort by title** or **Sort by date** buttons, as required. Press the buttons again to sort in reverse order.

To restore surveys sorted by ID, simply close and reopen the *Existing Surveys* screen.

7.3.4 Delete surveys

You can delete old surveys to free up disk space on the controller's internal storage.

▪ Delete a single survey

- a. In the home screen, press the  **Existing surveys** button.
- b. In the *Existing Surveys* screen, use the $\uparrow\downarrow$ arrow keys to select a survey.
- c. Press the **Delete survey** button.



▪ Delete multiple surveys

- a. In the home screen, press the  **Existing surveys** button.
- b. In the *Existing Surveys* screen, press the **Select multiple** button.

- c. Use the keyboard to select the surveys you want to delete. Use the \uparrow \downarrow arrow keys to highlight a survey. Then press Enter or the space bar to select the survey's check box. Or simply press the **Select all** button.
- d. To unselect a survey, you can clear its check box by pressing Enter or the space bar again. Or simply press the **Unselect** or **Unselect all** buttons.
- e. Press the **Delete selected** button to delete the selected surveys.



7.3.5 Rename a survey

By default, the survey title is set to the current date and time. But you can set a custom title:

- 1 In the home screen, press the  **Existing surveys** button.
- 2 In the *Existing Surveys* screen, open the survey you want to rename.
- 3 Press  **Edit survey header** button.
- 4 When the survey header screen opens, press the **Edit survey name** button.
- 5 In the *Set survey name* dialog, enter the new title and press the **OK** button.

7.3.6 Edit the survey header details

If required, you edit any header details in your existing surveys. Follow these steps:

- 1 In the home screen, press the  **Existing surveys** button.
- 2 In the *Existing Surveys* screen, open the survey you want to edit.
- 3 Press  **Edit survey header** button.
- 4 When the *Survey Header* screen opens, tab to the field you want and enter the new details.
 - The current field is highlighted in gray.
 - Mandatory fields are highlighted in yellow. Press the **Super tab** button or Tab key to tab through the mandatory fields only.
 - Press the \leftrightarrow \updownarrow arrow keys to move through *all* the header fields.
 - Fields with \updownarrow buttons have a drop-down menu. For drop-down menu shortcuts, see [page 166](#).

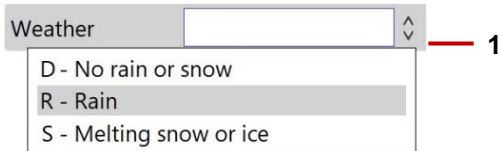

Fig. 7.4: Field with example drop-down menu. 1 Drop-down menu indicator.

- 5 Press the **Save** button.

7.4 Export a survey

You can export surveys to a USB memory stick, upload them to a Dropbox account, or send them to an email account. You can export individual surveys or you can export multiple surveys at the same time.

7.4.1 What is exported?

Depending on your chosen export method and export options, you can export all or some of the following:

- **Survey report (Microsoft Word DOCX):** The report is compliant with WRc MSCC standards, or French or Spanish EN13508 standards, as relevant. The exported file is [report.docx](#). For report details, see [page 163](#).

Note: *WinCan surveys are not exported in DOCX format.*

- **Survey report (XML):** Your flexiprobe C540c exports survey reports in XML format which can be used for importing your C540c surveys into some third party systems. The exported file is [export.xml](#).
- **Survey videos:** Survey videos are saved as MP4 files, encoded with H.264 video and MP3 audio. Exported files have unique digital names. For example, [1525787329255.mp4](#).

Note: *When discussing video formats, it is important to distinguish between video coding formats (such as H.264 or MPEG-4 Part 2), audio coding formats (such as AAC or MP3) and multimedia container formats (such as MP4 or AVI). Briefly, video content (encoded with a particular video*

coding format) is combined with an audio stream (encoded with an audio coding format) inside a container format.

List continues on next page.

- **Observation photos:** Still images captured from a survey video are saved as JPEG files. Exported files are numbered sequentially. For example, [1.jpg](#), [2.jpg](#), [3.jpg](#) and so on.
- **Target folder:** For exports to USB or Dropbox, surveys are exported to a [\[survey ID\]](#) target folder, where [\[survey ID\]](#) is the sequential ID number assigned to your survey by the controller. For an example, see [page 150](#).

Note: *You can only export survey videos and observation photos to USB or Dropbox. You cannot export them as email attachments.*

7.4.2 Export options

If exporting a survey to USB or Dropbox, you can choose any combination of export options.



If exporting a survey to email, you can only export the Microsoft Word survey report. You cannot export survey data & images or survey videos as email attachments.

- **Survey data & images:** Includes the survey report in XML format ([export.xml](#)), plus any observation photos. Note that photos are exported as JPEG images and numbered sequentially ([1.jpg](#), [2.jpg](#), [3.jpg](#) and so on).

- **Survey report:** Includes the survey report in Microsoft Word format ([report.docx](#)).
- **Videos:** Includes the survey videos. Survey videos are saved as MP4 files and have unique digital names (for example, [1525787329255.mp4](#)).

7.4.3 Connect to the internet

If you want to upload surveys to Dropbox or send them as email attachments, you must connect the controller to the internet before you start the export. The controller uses WiFi to connect to a suitable network. Follow these steps:

- 1 In the Home screen, press the  **Settings** button (item 6 on [page 32](#)).
- 2 Choose Settings > Network.
- 3 In the *Network Settings* screen, press the **Enable WiFi** button.
- 4 When the network list appears, use the   arrow keys to select the WiFi network you want. Then press the **Connect** button.

Wait while the controller connects to the selected network.

If the WiFi network has internet access, the connection icon changes to  and “**(online)**” is appended to the network name.

Note: To switch to a different WiFi network, see [page 140](#).



5 If you chose a secure network, the controller prompts you for the network password.

By default, password characters are obscured, but you can click the **Show password** button to display the actual characters. This can be useful if you are unsure whether Caps Lock is on.

Note: *The Network Settings screen is described on [page 79](#).*

7.4.4 Switch to a different WiFi network

If the controller is currently connected to a WiFi network, you must first disconnect from that network before you can connect to a different network. Follow these steps:

1 In the *Network Settings* screen, use the   arrow keys to select the WiFi network you are currently connected to. Then press the **Disconnect** button.

The connection icon reverts to  ('not connected').

2 Use the   arrow keys to select a new WiFi network you want. Then press the **Connect** button.

Wait while the controller connects to the new network.

If the new WiFi network has internet access, the connection icon changes to  and **“(online)”** is appended to the network name.

7.4.5 Select surveys for export

Follow these steps

- 1 (Email and Dropbox export only) Connect the controller to the internet; see [page 139](#).
- 2 In the home screen, press the  **Existing surveys** button.
- 3 In the *Existing Surveys* screen, select the surveys you want to export:

Export a single survey: Use the $\uparrow\downarrow$ arrow keys to select a survey. Then press the **Export** button.

Export multiple surveys: Follow these steps:

- a. Press the **Select multiple** button.
 - b. Use the $\uparrow\downarrow$ arrow keys to highlight a survey. Then press Enter or the space bar to select the survey's check box.
 - c. Repeat step b. for each survey you want to export. Or simply press the **Select all** button.
 - d. Press the **Export Selected** button
 - e. Choose whether to export the surveys as a single project or as individual surveys, then press **Select**. For a single project, give the project a name, then press **OK**.
- 4 In the *Export* menu, choose the export method and press OK:
 - **Export to USB:** Continue to [page 142](#).
 - **Export as email attachment:** Continue to [page 143](#).

- **Export to Dropbox:** *Only available if exporting a single survey.* Continue to [page 151](#).

7.4.6 Export to USB

After choosing USB as the export method, follow these steps:

- 1 If you have not already done so, insert a USB memory stick into one of the controller's USB ports.
- 2 In the *Select USB disk* screen, select your USB memory stick.
- 3 (*Optional*) Specify the survey options; see [page 138](#). That is, choose which items to export:
 - a. Press the **Export options** button.
 - b. Use the keyboard to select the items you want to export. Use the \uparrow \downarrow arrow keys to highlight an item. Then press Enter or the space bar to select its check box.
 - c. Press the **Save** button to save your export selections.
- 4 Still in the *Select USB disk* screen, press the **Continue** button to export the survey(s).

7.4.7 Export as email attachments

Note: *You can only export survey reports as email attachments. You cannot export survey videos or observation photos as attachments.*

After choosing Email as the export method, follow these steps:

- 1 (Optional) If required, press the **Network settings** button to connect to a different WiFi network.
 - 2 (Optional) If required, press the **Email settings** button to change the email sender and server details.
 - 3 In the *Send Email* screen ([page 144](#)), you must specify the email recipient(s). You can also write a brief message.
- **Recipients:** To quickly choose a previous recipient, press the **Recipients** button. In the pop-up address book, use the $\uparrow\downarrow$ arrow keys to highlight a recipient. Then press Enter to select their check box. Finally, press the **Add recipients to email** button. For details, see [page 145](#).
 - **Message:** The email subject and filename for the attached report are defined automatically, based on the survey title, but you can edit them if required.
- 4 Press the **Send** button to finish exporting the survey.

The image shows a 'Send email' interface with a white background and a black border. At the top, there is a black header bar with the text 'Send email' in white. Below the header, the text 'New email' is displayed. There are four numbered callouts on the left side, each with a red line pointing to a specific field:

- 1** points to the 'To:' field containing the email address 'frank.schaeffer@spxdetection.com'.
- 2** points to the 'Subject:' field containing the text 'report_2018-05-04'.
- 3** points to the 'Message:' field, which is a large text area containing the text 'Sewer survey for Western Avenue, Bristol'.
- 4** points to the 'Attached filename:' field containing the text 'report_2018-05-04.docx'.

Fig. 7.5: Send email screen. 1 Recipient. 2 Subject. Can be edited. 3 Optional Message. 4 Attachment filename. Can be edited.

7.4.8 Email send failure

If your email failed to send, possible reasons include:

- 1 Email address and/or password was entered incorrectly – try re-entering these fields.
- 2 Hostname, port or SSL setting are incorrect
- 3 Your email security settings **may need** to be adjusted, which may require you to login to your e-mail account from a PC or mobile device. An example of the Gmail security settings is shown below (current as of writing this manual). For other e-mail providers, you may need to modify the settings accordingly.

To edit the Gmail security settings, visit <https://myaccount.google.com/> and sign into your account. You will then see the screen below. Click on **Security** and then **Get Started**.

Google Account

Search Google Account

Home

Personal info

Data & personalization

Security

People & sharing

Payments & subscriptions

Help

Send feedback

Welcome, Respected Surveys

Manage your info, privacy, and security to make Google work better for you

Review your privacy settings
Take the Privacy Checkup, a step-by-step guide that helps you choose your privacy settings
[Get started](#)

Security issues found
Protect your account now by resolving these issues
[Secure account](#)

Make Google yours
See the data in your Google Account and choose what activity is saved to personalize your Google experience
[Manage your data & personalization](#)

Account storage
Your account storage is shared across Google services, like Gmail and Photos
0% used – 0 GB of 15 GB
[Manage storage](#)

Only you can see your settings. Google is committed to protecting your privacy and security. [Learn more](#)

Fig. 7.6: Gmail account home

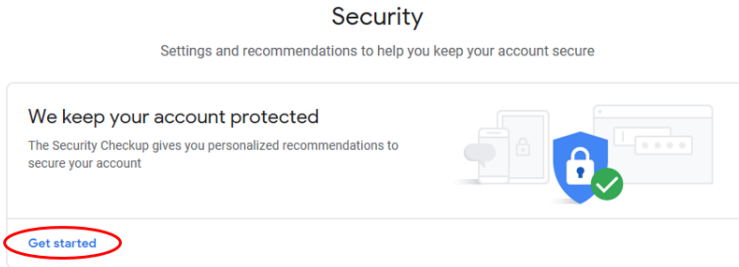

Fig. 7.7: Gmail Security

Scroll down to **Less secure app access** and click on **Turn on access (not recommended)**.

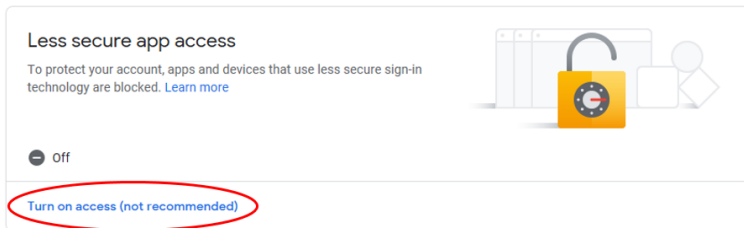

Fig. 7.8: Gmail Less secure app access

Finally, click on the slider to turn the less secure access on

← Less secure app access

Some apps and devices use less secure sign-in technology, which makes your account more vulnerable. You can **turn off** access for these apps, which we recommend, or **turn on** access if you want to use them despite the risks. [Learn more](#)



Fig. 7.9: Gmail Less secure app access

7.4.9 Manage email recipients

When you send a survey by email, the recipients are saved automatically to an address book. You can quickly add these recipients again when sending new surveys.

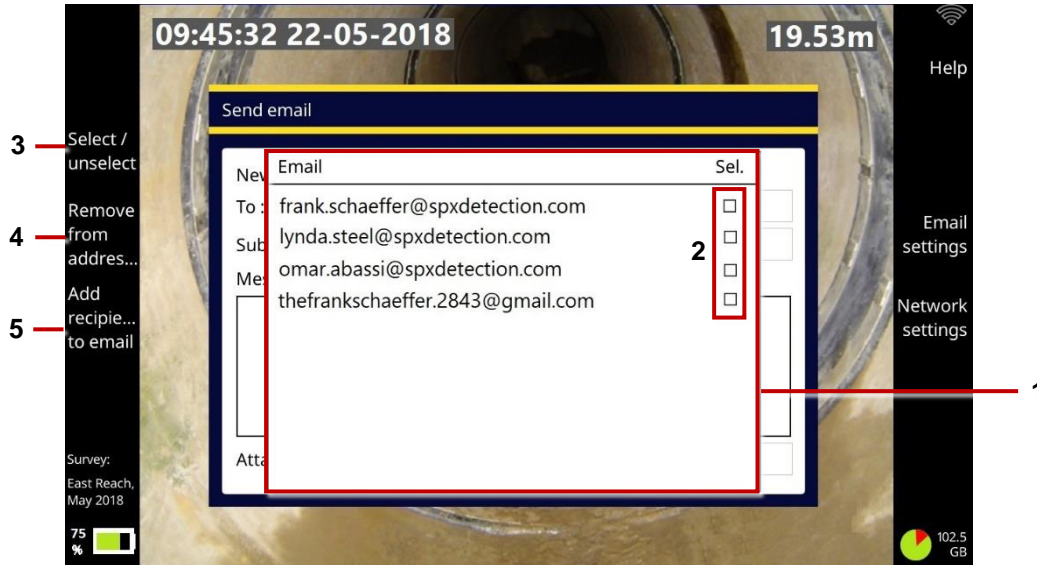

Fig. 7.10: Managing email recipients. 1 Address book. 2 Recipient check boxes. 3 Select/unselect button. 4 Remove from address book button. 5 Add recipients to email button.

To manage recipients in the address book:

- 1 Use the ↑↓ arrow keys to highlight a recipient.
- 2 Press Enter to select (or clear) the recipient's check box. Or press the **Select/unselect** button.
- 3 Do one of the following:
 - Press the **Add recipients to email** button to add selected recipients to your email.
 - Press the **Remove from address book** button to delete selected recipients.

7.4.10 Export to Dropbox

Note: *You can only export single surveys to Dropbox. If you are exporting multiple surveys, the Dropbox export method is not available.*

After choosing Dropbox as the export method, follow these steps:

- 1 (Optional) If required, press the **Network settings** button to connect to a different WiFi network.
- 2 (Optional) If required, press the **Dropbox settings** button to change or update the authentication details for a valid Dropbox account. See [page 85](#).
- 3 (Optional) Specify the export options; see [page 138](#). That is, choose which items to export:
 - a. Press the **Export options** button.
 - b. Use the keyboard to select the items you want to export. Use the \uparrow \downarrow arrow keys to highlight an item. Then press Enter or the space bar to select its check box.
 - c. Press the **Save** button to save your export selections.

- 4 In the *Export to Dropbox* dialog, specify the **Dropbox destination**. This is the target subfolder that will contain your uploaded survey.

Surveys are always uploaded to a subfolder below the [\Pearpoint Cloud](#) folder. By default, this subfolder is based on the controller ID and survey ID but you can specify a custom subfolder.

See [page 153](#) for a full description of the default Dropbox destination.



Fig. 7.11: Export to Dropbox dialog

- 5 Press the **Export** button to start the export.

See the next section for details about where to find your survey files in Dropbox.

7.4.11 Where is my survey in Dropbox?

When you log in to Dropbox, you can find your uploaded survey files in this subfolder:

[Files](#) > [Apps](#) > [Pearpoint Cloud](#) > [\[Controller ID\]](#) > [\[Survey ID\]](#)

Where [\[Controller ID\]](#) is the serial number that uniquely identifies the controller unit used for the survey and [\[survey ID\]](#) is the sequential ID number assigned to your survey by the controller. In the example below, the survey is uploaded to the [\survey0000002](#) folder.

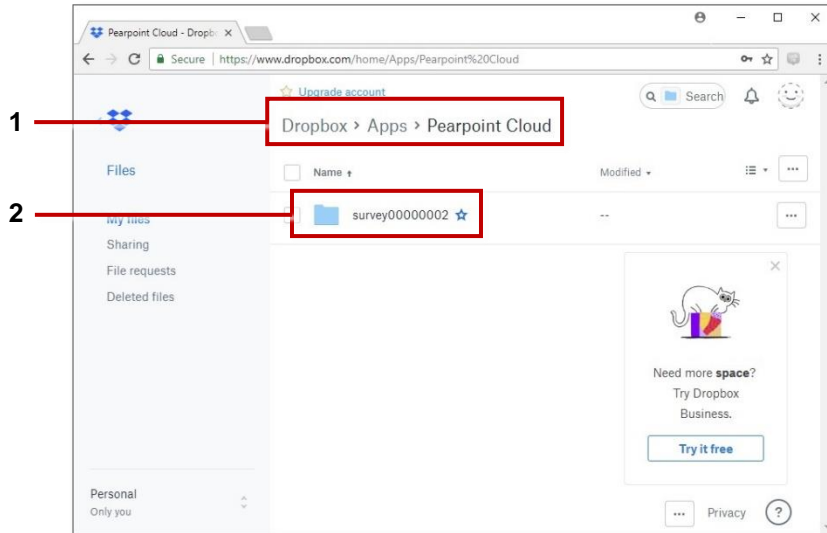

Fig. 7.12: Dropbox files screen.

- 1 Path to 'Pearpoint Cloud' folder.*
- 2 Folder containing exported survey.*

7.5 Observations

Observations form an essential part of your survey report. Observations are used to give a detailed yet concise description of your findings. For example, you can record pipe defects, connections, and debris.

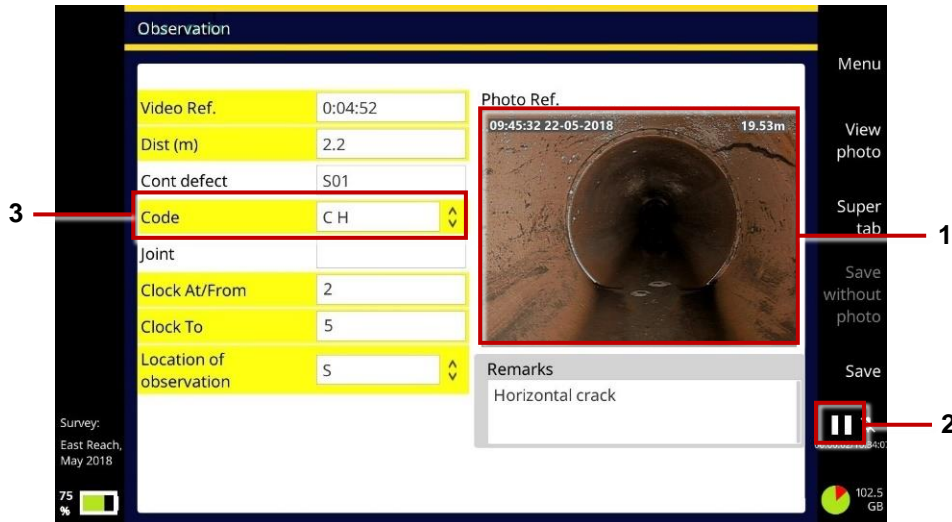

Fig. 7.13: Example observation with (1) photo. Video recording pauses automatically (2) while you add the observation details. Select a condition code (3) to identify the defect type.

An observation typically includes the camera distance, a photo (screenshot), the condition code, plus any additional comments. Observations are usually entered sequentially as you conduct your survey.

You can add observations while recording a new survey video or while playing back an existing video.

Observations and associated photos are listed in survey reports when you export a survey. They are also recorded on sewer and manhole diagrams in your survey reports; see [page 163](#).

7.5.1 Condition codes

For MSCC structured surveys, the controller supports WRc's MSCC condition codes for drains & sewers and manhole/inspection chambers. For French and Spanish structured surveys, the controller supports the relevant EN13508 standards. These condition codes describe the physical condition of the pipe or manhole/inspection chamber and the severity of the condition.



These condition codes are available as drop-down menu options in all observation forms for structured surveys, saving you time and ensuring consistency.

To allow fast data entry, you can type the code directly (if you know it). For example, type '**DE**' for debris. Or to list a subset of condition codes, you can type the initial letter. For type '**D**' to see all condition codes beginning with 'D', including codes for debris, deformed sewers, and displaced brocks.

For full descriptions of all condition codes, see the latest *WRc Manual of Sewer Condition Classification*. This manual is available on the Publishing page on the WRc website, www.wrcplc.co.uk/publishing.

7.5.2 Add an observation

Follow these steps:

- 1 Start recording a new video ([page 105](#)) or play back an existing video ([page 121](#)).
- 2 If recording a video, press the  *panel button* ([page 31](#)) or  **New Observation** button ([page 121](#)).
If replaying a video, press the **New observation** button ([page 121](#)).
- 3 The video recording or playback pauses automatically and the controller saves a photo.
The photo shows exactly what is on the screen at the time, including any camera rotation, date & time and camera distance. (These on-screen details are configurable; see [page 74](#)).
- 4 In the *New Observation* screen, fill in the fields required by the survey standard.
 - The current field is **highlighted in gray**.
 - Mandatory fields are **highlighted in yellow**. Press the **Super tab** button or Tab key to tab through the mandatory fields only.
 - Press the $\leftarrow \rightarrow \uparrow \downarrow$ arrow keys to move through *all* the observation fields.

List continues on next page.

- The **Code** field has a  button, indicating a drop-down menu (see next page). For drop-down menu shortcuts, see [page 166](#).
- Some observation types (for example, broken pipe, cracks and defective connections) require a *clock reference*; see [page 162](#).

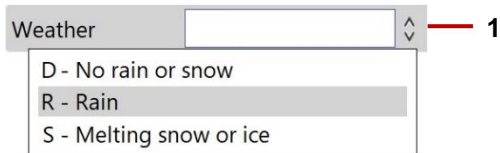

Fig. 7.14: Field with example drop-down menu. 1 Drop-down menu indicator.

- 5 Press the **Save** button to save the observation details.
Alternatively, press the **Save without photo** button. For example, you may choose this save option if vision has been lost because the camera has gone underwater.

7.5.3 Jump to observations when playing back a video

You can quickly review video segments that correspond to observations when you play back a video. Follow these steps:

- 1 Play the video; see [page 121](#).
- 2 Press the **Next observation** button to jump to each observation in turn.

Note: *You can also use the **Next observation** button while the video is paused.*

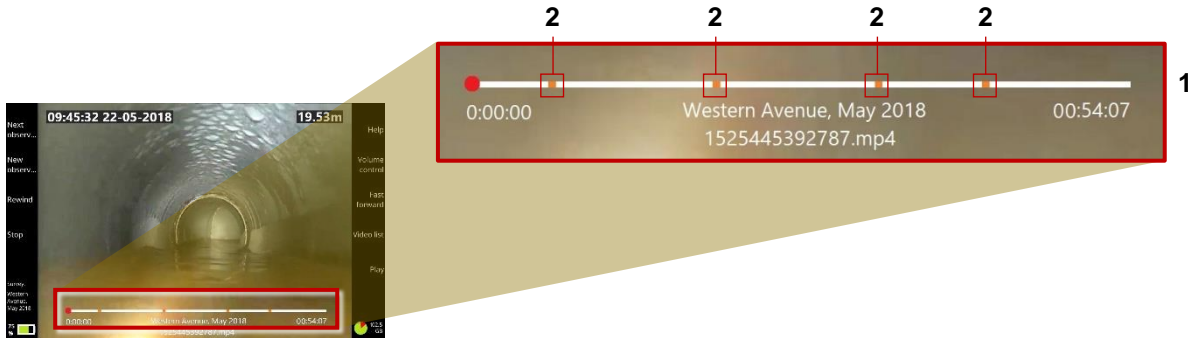



Fig. 7.15: Video progress bar (1) showing position of observations (2)

7.5.4 View or edit an observation

Follow these steps:







- 1 In the home screen, press the  **Existing surveys** button.
- 2 Open the survey that you want to manage.
In the *Edit Survey* screen now displays; see [page 132](#).
- 3 In the *Edit Survey* screen, press the  **List observations** button.
- 4 In the *Observation List* screen, use the ↑ ↓ arrow keys to select the observation you want.
- 5 Press the Enter key or the **Open** button.
- 6 In the *Observation* screen, edit the fields as required; see [page 156](#) for guidance.

7.5.5 Delete observations





Note: *If you delete an observation, the associated photo is also deleted and cannot be recovered.*

Follow these steps:

▪ Delete a single observation

- a. In the home screen, press the  **Existing surveys** button
- b. In the *Existing Surveys* screen, open the survey with the observations you want to delete. Use the   arrow keys to select a survey.
- c. In the *Edit Survey* screen, press the  **List observations** button.
- d. In the *Observation List* screen, use the   arrow keys to select an observation
- e. Press the **Delete observation** button. You will be asked to confirm, by pressing the **Confirm delete** button.

▪ Delete multiple observations

- a. In the home screen, press the  **Existing surveys** button
- b. In the *Existing Surveys* screen, open the survey with the observations you want to delete. Use the   arrow keys to select a survey.
- c. In the *Edit Survey* screen, press the  **List observations** button.

- d. Press the **Select multiple** button.
- e. In the *Observation List* screen, use the $\uparrow\downarrow$ arrow keys to highlight an observation. Then press Enter or the space bar to select its check box.
- f. Repeat the previous step each observation you want to delete. Or press the **Select all** button.
- g. Press the **Delete selected** button. You will be asked to confirm, by pressing the **Confirm delete** button.

7.5.6 Clock references

Many observations require a clock reference to locate the defect's position on the pipe wall. For example, you can observe a circumferential crack extending from 2 o'clock to 5 o'clock:

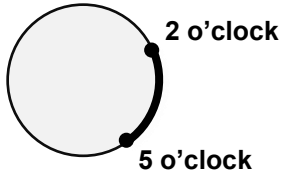

To help you record these defects accurately, when you type 1 to 12 in a Clock field, a pop-up observation photo is shown with a superimposed clock face that highlights your clock references.

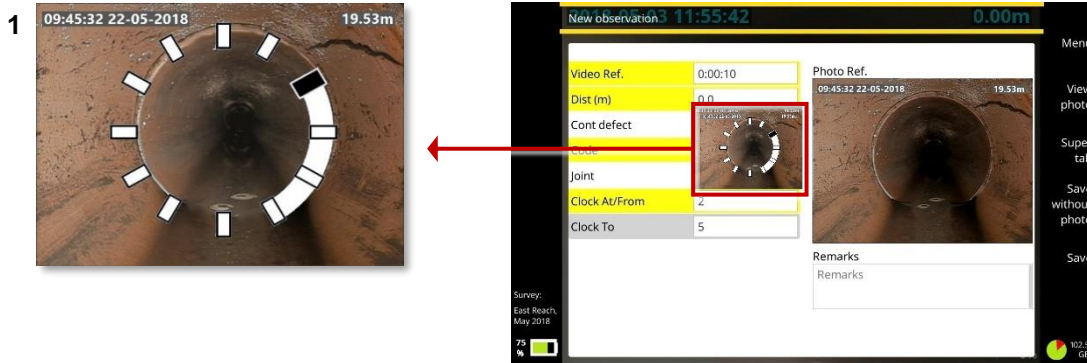

Fig. 7.16: Entering a clock reference. 1 Clock face on pop-up photo illustrates the clock references. In this example, a circumferential crack is observed from 2 o'clock to 5 o'clock.

7.6 Reports

A survey report is generated when you export a survey ([page 137](#)). Reports are generated in DOCX and XML format. The report includes the survey header details plus any observations.

For DOCX reports, a title page shows your company details and (if specified) your company logo. The report also includes observation photos and a drain/sewer diagram or manhole/inspection chamber diagram, showing the relative locations of the individual observations; [see pages 164 and 165](#).

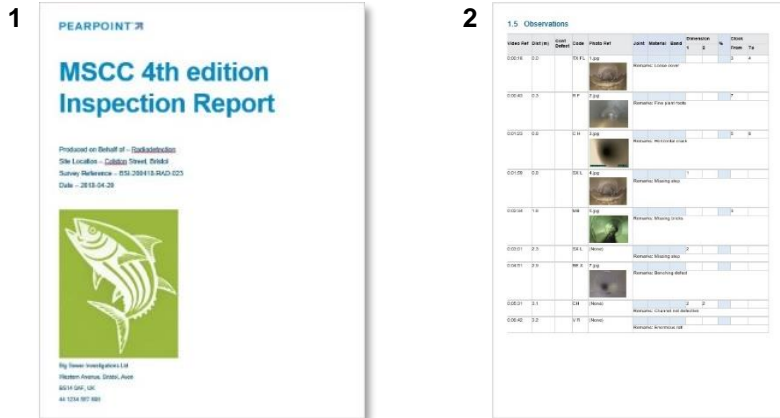
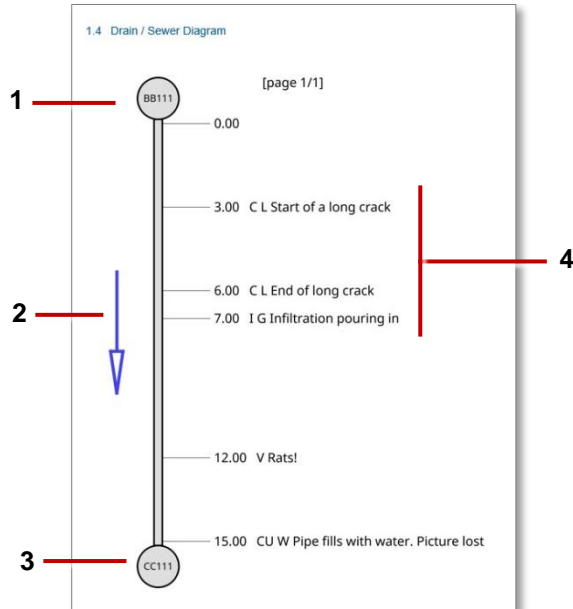

Fig. 7.17: DOCX survey report. 1 Example title page with company details and logo. 2 Observations page. Observations are presented in tabular form with thumbnail photos.

7.6.1 Drain and sewer diagrams

These diagrams are included in MSCC *Drain/Sewer* survey reports; see [page 166](#) for the full survey list.



- 1 *Start node reference*
- 2 *Direction. Shows whether the camera was pointing downstream (with the flow) or upstream (against the flow)*
- 3 *Finish node reference*
- 4 *Observations. For each observation, the diagram shows the distance and code, plus any remarks.*

Fig. 7.18: Example drain/sewer diagram for survey report.

7.6.2 Manhole and inspection chamber diagrams

These diagrams are included in MSCC *Manhole/Inspection Chamber* survey reports; see [page 165](#) for the full survey list.

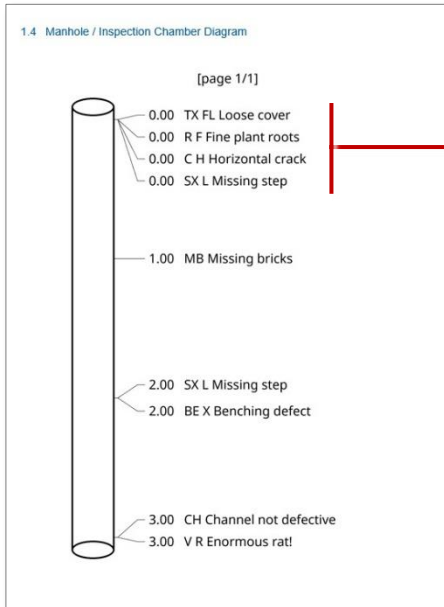

Observations. For each observation, the diagram shows the depth (vertical distance) and code, plus any remarks.

Fig. 7.19: Example manhole/inspection chamber diagram for survey report.

7.7 Video streaming

You can stream the video images showing on the display of the flexiprobe C540c to a nearby connected device, such as a cell phone or tablet by following these steps:

1. Connect your device as a hotspot to the flexiprobe C540c
2. Open the Settings menu, then the Networks item
3. Scroll to “Enable video streaming” and activate
4. Note the IP address in the “WiFi IP” box

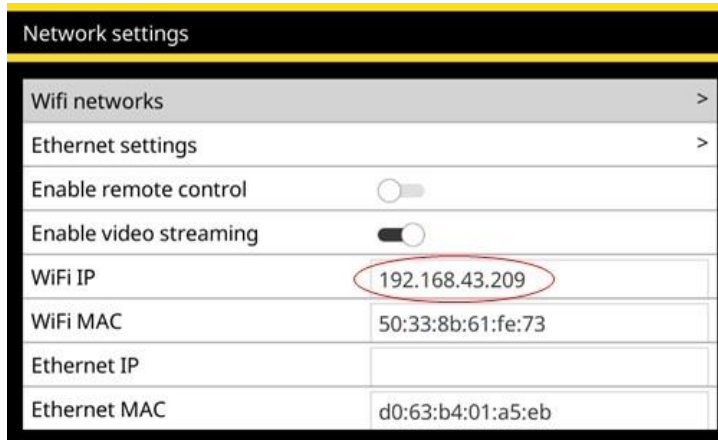

5. Open Safari (12 or newer), Chrome (71 to 73) or Microsoft Edge (contact CUES for version information) on your device, type the noted IP address into the browser address bar and press Go.

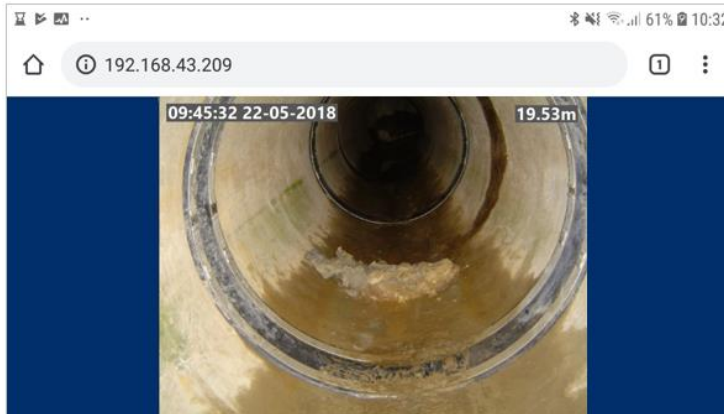



6. The streamed video will show in the browser, as shown above.

If you encounter difficulties, check that your browser is compatible with this feature (see step 5 above). Also move your device closer to the flexiprobe C540c to ensure a good connection between the two units. Some devices are incompatible with the video streaming feature. Contact CUES for additional and updated information.

7.8 Menu shortcuts

When you create a new survey or add an observation, fields with  buttons have a drop down menu.

- Press Enter to display the drop-down menu.
- Press the   arrow keys to select the menu item you want. Then press Enter again.
- Type one or more letters to filter the menu by item(s) starting with those letters.

Example: In a **Weather** field, type 'r' to automatically select 'R - Rain'.

Example: In a **Code** field, type 'fw' to filter the menu to only show flow codes such as 'FW C - Clear flow' and 'FW T - Turbid flow'.

- You can also filter the menu by typing any text that appears in a menu item *description*.

Example: In a **Code** field, type 'oxygen' to filter the menu to only show codes with a matching description such as 'OD – Hazardous atmosphere, oxygen deficiency'.

Note: You cannot type (or) characters to filter a drop-down menu.

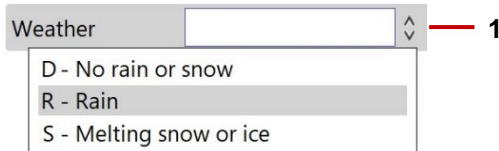

Fig. 7.20: Field with example drop-down menu. 1 Drop-down menu indicator.

7.9 Supported survey standards

The C540c controller currently supports the following survey standards. Survey header details for these standards contain condition codes relevant to each standard.

- MSCC3
- MSCC4 Domestic (Drain/Sewer)
- MSCC4 Sewerage (Drain/Sewer)
- MSCC4 Sewerage (Manhole/Inspection Chamber)
- MSCC4 Highways (Drain/Sewer)
- MSCC5 Domestic (Drain/Sewer)
- MSCC5 Sewerage (Drain/Sewer)
- MSCC5 Sewerage (Manhole/Inspection Chamber)
- MSCC5 Highways (Drain/Sewer)
- MSCC5 Domestic (Manhole/Inspection Chamber)
- EN13508-FR
- EN13508-ES

Note: *MSCCx refers to the Manual of Sewer Condition Classification 3rd, 4th or 5th Edition.*

7.9.1 WinCan-compliant surveys – option

The C540c can support users who wish to generate reports compliant with WinCan reporting PC software. In the *Create survey* menu, select *WinCan survey* from the *Format* drop-down menu

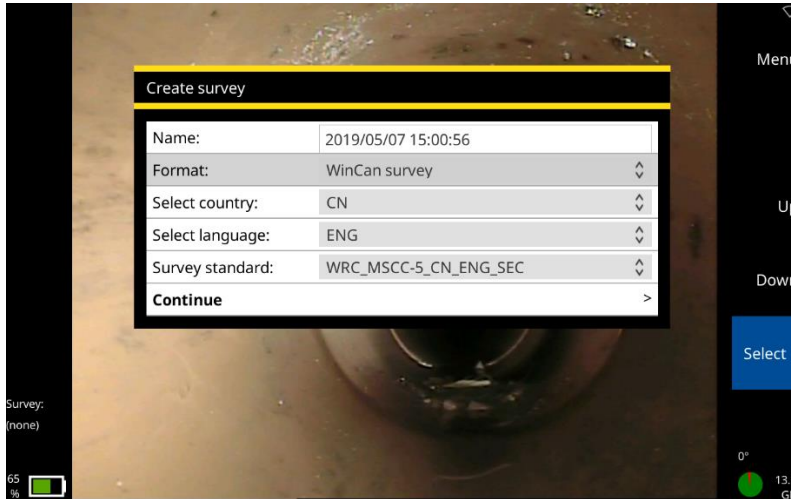

Fig. 7.21: Create survey menu showing WinCan survey as the format type.

Please see [page 89](#) for guidance on enabling your C540c to create WinCan-compliant surveys.

Performing surveys

Surveys are performed in the same way as other surveys.

WinCan survey reports

Users can export to USB, or using a WiFi hotspot, by email and DropBox. Exports to DropBox and via email contain an xml format file that can be imported into a WinCan-enabled PC. Exports to USB will also contain a copy of the mp4 video file.

8 Maintenance and cleaning

8.1 Maintenance



Warning! *Do not dismantle any component parts. This could invalidate your warranty and exposed metal or electrical devices may be hazardous and/or electrically live. We do not permit user-servicing of our systems.*

We recommend that you only assemble or disassemble system components (for example, attaching the camera to the rod) in a dry and clean environment.

We recommend that only authorized service centers carry out service of this product. If this product is serviced elsewhere, this will invalidate your warranty.

8.1.1 Storing the system

The C540c is a precision system. Always store the system, including all components and accessories, in a clean and dry environment.

8.1.2 Connection points, terminals and O-rings

Caution: *Do not use damaged, dirty or corroded components, including all terminal connections, cables and O-rings.*

Ensure that all terminals and connection points are clean and free of corrosion and debris before you attempt to use this equipment. This particularly affects the link cable connections between the controller and reel, and the pushrod connection to the camera.

Check that any O-rings are clean, greased and not damaged. This particularly applies to the camera O-rings. For example, use a silicon-based grease such as "Super Lube" on the O-rings only.

Do *not* apply grease or lubricant to any pogo pins or the slipping PCB. This particularly applies to the connection behind the camera.

We recommend protecting all terminals with plastic protective caps when the system is not in use.

8.1.3 Rod guide assembly

Always make sure the rod guide is clean.

Check the rod guide assembly regularly to see if a replacement is needed. Spare rod guides can be purchased and fitted by competent mechanical technicians using a screwdriver. Spare rods and various components are available to purchase as repair kits.

Caution: *If the rod wears through the rod guide, it will start to wear through the metal structure of the coiler. Wear to the metal components can cause hazards for the operator (sharp edges or electrical malfunction).*



Fig. 8.1: Rod guides. 1 Fitted on 541 and 542 reels. 2 Fitted on 543 reels.

For servicing information, contact CUES Technical; see [page 21](#). Or contact your CUES representative.

8.2 Cleaning the system



Warning! *Foul water systems can be a source of biological hazards. Use appropriate gloves when cleaning the system. Always disinfect the camera and pushrod after use.*

Caution: *Do not use high-pressure hoses to clean this system.*

To help prevent the risk of biological contamination, clean and sanitize the C540c with a suitable disinfectant at regular intervals and after conducting an inspection. When cleaning the system, consider your working environment.

- **Camera:** Clean water and disinfectant. Clean the lens with a lint-free cloth.
- **Pushrod:** Always clean and disinfect the rod after use. Use a cloth moistened with disinfectant.
- **Controller:** Clean the case with mild soapy water. Use a lint-free cloth to clean the LCD screen.
- **If you need to ship the system:** Clean and sterilize the system before shipping. Always follow any applicable laws and guidelines.

8.3 Factory reset

This section describes how to perform a factory reset. This will restore the controller to its original state, erasing any configuration settings currently defined on the device. You must only perform a factory reset if instructed to do so by CUES technical staff.

Follow these steps:

- 1 In the Home screen, press the  **Settings** button (item 6 on [page 32](#)).
- 2 Choose Settings > Maintenance > Factory Reset.
- 3 When the controller restarts, a setup wizard launches automatically. The wizard comprises several menus where you can set preferences and basic details.

Briefly, you will need to re-specify the language, the system date & time, the keyboard layout and your preferred distance units (feet or meters). The wizard also prompts you for your company details; the controller will use these details to personalize the title page of your survey reports.

For full details about the setup wizard, see [page 64](#).

9 Software updates

CUES may issue C540c software updates to enhance system performance. We strongly recommend that you periodically check for new software releases and update your controller when new software is made available. Controller software updates are free of charge.

Updating the software is straightforward. Follow these steps:

- 1 When the controller connects to the internet (see [page 139](#)), it automatically compares your current software with the latest version available on the CUES web site. If a newer version is available, it displays a Software Update advisory. Go to step 2.

Alternatively, you can manually check whether a software update is available.

- a. Check your controller's current software version. On the controller, select Settings > Maintenance > Software versions.
 - b. Check the latest version available on the CUES web site. Go to step 2.
- 2 Now download the software update. Follow these steps:
 - a. Browse to www.cuesinc.com and go to the C540c product page.
 - b. Scroll down to the Software section.
 - c. If a newer software version is available, download the newer version. The download file is:
[dvc2-<n.n.n.n>.rdu](#)
Where <n.n.n.n> is the controller software version.

- 3 Copy the downloaded file to the root of a USB memory stick.
- 4 Power off the controller.
- 5 Insert your USB memory stick into your controller.
- 6 Connect the controller to the mains power supply and power on.

Caution: *Always connect the controller to the mains supply before updating the software. This ensures a reliable power source.*

- 7 On your controller, select Settings > Maintenance > Software Update and follow the on-screen instructions.
- 8 Wait while the controller updates the software. This process may take several minutes

Caution: *Do not switch off the controller or remove the USB memory stick while the upgrade is in progress. Interrupting the upgrade may leave the controller inoperable.*

- 9 When the update is complete, the controller prompts you to restart.
When the controller restarts, the update process is complete.

10 Specifications

10.1 Controller specifications

Specification	Description	
Mains power supply	AC adapter input	100-240VAC 50-60Hz 1.7A
	AC adapter output	16VDC 3.75A 60W
Automotive power supply	Automotive battery input	10-30VDC 4.0A
Battery capacity	14.4V 6.5Ah (94Wh)	
Battery runtime	4-6 hours depending on usage	
Display	10" (25.4cm) industrial TFT LCD screen	
Data storage	128 GB	
Connectivity	x3 USB	HDMI out
	3.5mm mic in / headphone out	RCA video in
Environmental protection	IP55 (with covers closed or open)	
Temperature	Storage	-4° to 176° F (-20° to +80° C)
	Operating	14° to 122° F (-10° to 50° C)
	Charging	32° to 104° F (0° to 40° C)
Dimensions (H x W x D)	With closed covers: 15.4 x 17.1 x 5.5" (390 x 435 x 140 mm)	
Weight	15.8 lbs (7.2 kg)	

10.2 Reel and rod specifications

	541 Plumbers	541	542	543
Dimensions (H x W x D)	22.4 x 16.9 x 10.6"	22.4 x 16.9 x 10.6"	33.5 x 29.5 x 16.5"	32.0 x 46.0 x 18.7"
	570 x 430 x 269 mm	570 x 430 x 269 mm	850 x 750 x 420 mm	813 x 1168 x 475 mm
Weight	21 lbs (9 kg)	24 lbs (11 kg)	40 lbs (18 kg)	82 lbs (37 kg)
	27 lbs (12 kg)		55 lbs (25 kg)	
Construction	Powder-coated tubular steel frame			
Rod length	100' (30m)	115' (35m)	200' (60m)	500' (150m)
	200' (60m)		400' (120m)	
Rod diameter	7.5 mm MK1	12.0mm	11.3mm	11.5mm
	9.5 mm MK2			

10.3 Camera specifications

	1" / 25mm	1¼" / 32mm	2" / 50mm
Dimension	1.0 x 1.5" (25 x 39 mm)	1.23 x 2.6" (31 x 66 mm)	1.9 x 2.9" (48 x 73 mm)
Weight	0.1 lbs (60 g)	0.4 lbs (180 g)	0.8 lbs (360 g)
Construction	Stainless steel / polycarbonate	Stainless steel / sapphire glass / polycarbonate	
Power	1.8W	1.3W	3.8W
Environmental	IP68 to 330' (100m) / 11bar	IP68 to 230' (70m) / 7bar	IP68 to 330' (100m) / 11bar
Focus	Adjustable	Fixed	Adjustable
Focal Range	10mm to ∞	Fixed	10mm to ∞
Lighting	Ultra-bright white LEDs	Ultra-bright white LEDs	Ultra-bright white LEDs
LED luminance	≥ 75 lm	≥ 150 lm	≥ 208 lm
Active Pixels (H x V)	656 x 492 NTSC 768 x 576 PAL	640 x 480 NTSC 640 x 576 PAL	768 x 492 NTSC 765 x 582 PAL
Horizontal resolution	≥ 460TVL	≥ 420TVL	≥ 460TVL

11 Open Source Software

The software included in this product contains copyrighted software that is licensed under the GNU General Public License (GPL), GNU Lesser Public License (LGPL), and other open source licenses.

Further information including a copy of each license is located in the product on-screen menu under:

Maintenance > Open source software

You may obtain the complete Corresponding Source code from us for a period of three years after our last shipment of this product by sending an email to: DL-PP.Service.US@spx.com

If you require the complete Corresponding Source code to be supplied on a physical medium such as DVD the cost of physically performing the distribution may be charged.

You may also find a copy of the source at <https://cuesinc.com/pages/cues-c540c-software-updates>

This offer is valid to anyone in receipt of this information.

Index

A

accessories.....	41
address book	149
audio commentary	
adding	119
adjust volume	122
listening to	120
auto-connect	82
auxiliary connection panel.....	30
auxiliary video source.....	73

B

battery.....	34, 57
charge before first use.....	58
if low charge	59
lifespan, how to prolong.....	34
lifespan, typical.....	35
safety precautions	10

temperature, effect on charging.....	34
before you begin	2
biological precautions	9
brightness	72
brushes.....	40
attaching.....	52

C

calibration	100
definition.....	19
reminder on startup	101
cameras	
attach to rod	47
available types.....	38
clean after use!.....	127
cleaning.....	175
deploy into pipe	102
focusing.....	47
retrieve from pipe	127

rotating the video feed	113
safety precautions	11
specifications	181
zero the distance	103
charger	
mains	41
vehicle charging cable	41
cleaning the system	175
clock reference	162
coiler	See <i>reels</i>
company details	91
company logo, importing	92
compliance	4
condition codes	155
connection panel	
auxiliary	30
main	29
connection points	173
controller	
cleaning	175
front view	25

handle-mounted status indicators	28
home screen	32
overview	24
power on	63
rear view	27
specifications	179
Controller settings	72

D

date and time, setting	65
daylight saving time	65
debug log	89
delete a survey	134
diagnostics	89
diagrams	
drain and sewer	164
manhole and inspection chamber	165
disposal of the system	11
distance units, setting	66
drain and sewer diagrams	164
Dropbox	
export to	151

file location 153
set up connection 85
Dropbox Settings 85
drop-down menus 168
DST See *daylight saving time*

E

Edit survey screen 131
electrical precautions 8
email recipients 149
Email settings 84
email, exporting to 143
Equipment settings 77, 78
export a survey 137
export options 138
external video equipment 57

F

factory reset 176
fast forward a video 122
FAT32 89
flexi 39, See *universal flexi*

flexisondes 39, 50
focus tool 48
focusing the camera 47

H

handle-mounted status indicators 28
header details, editing 136
headset 45
home screen 32

I

idle settings 88
internal storage 44
internet connection 139

K

keyboard 45

L

language, choosing 64
layout choice, for screen overlays 75
lithium-ion battery See *battery*
log files 89

M

main connection panel	29
mains charger	41
maintenance	172
Maintenance settings	88
manhole and inspection chamber diagrams	165
memory sticks, USB.....	45
menu scrolling wraps around	72
menu shortcuts	168
mounting the controller.....	44
mouse, not supported	45
moving the system	11

N

network	
connect to.....	139
list of available networks.....	81
Network settings.....	79
NTFS, not supported.....	89

O

observations	154
--------------------	-----

adding	156
condition codes	155
delete	160
editing	159
input form	154
jump to	158
opacity, text background	76
open a survey	133
open source software.....	182
O-rings.....	173
overlay text and shapes	
adding	116
screenshot.....	116

P

panel buttons	31, 106
password for email sender	84
photos	
exporting	138
in survey reports.....	163
taking	113, 123
playing back videos.....	121

port 84
power management 88
power on the controller..... 63
pushrod reel
 connect to controller 46

Q

quick start 22

R

rechargeable battery See *battery*
recipients, managing 149
recording a video
 storage capacity of controller 44
recording a video 108
recording a video 109
recording a video
 extra videos for current survey 111
reels
 available models..... 36
 connect to controller 46
 features 37

Reel power off/on 77, 78
Reel type 77, 78
reel type, selecting 100
safety precautions 9
specifications..... 180
rename a survey 135
replaying videos..... 121
reports 163
 exporting 137
rewind a video..... 122
rewind the pushrod 100
risk assessment 7
rod
 cleaning..... 175
 rewind at startup..... 100
 rod guide, cleaning 174
 specifications..... 180
rotate the video feed 113

S

safety notices..... 20
safety precautions..... 8

scan	83
Screen overlay settings.....	74
search for a survey	133
server, email	84
Settings menus	69
using	70
setup wizard.....	64
shipping the system	175
shortcuts, for drop-down menus.....	168
skids	40
attaching.....	52
w-skids	56
SMTP username	84
software updates.....	177
software versions	89
sondes	39, 50
sort the survey list	134
specifications	179
SSID	81
status indicators	
handle-mounted	28

video recording.....	107
storage capacity of controller	44
storing the controller	172
surveys	128
create	128
deleting	134
Edit survey screen.....	131
Existing surveys screen.....	132
exporting	137
header details.....	136
managing	132
open a survey.....	133
rename.....	135
search for	133
sorting	134
WRc MSSC standards.....	169

T

TCP port	84
terminals	173
Text background opacity	76

title page

custom page.....	94
designing.....	97
enable	97
set up	93
settings	76, 77
TLS check box	84
trademarks.....	3
training.....	20

U

universal brush and skid set.....	52
updates	177

USB

exporting to	142
front controller port	26
rear controller ports	30
USB memory sticks.....	45
FAT32, reformatting to.....	89

V

vehicle	
charging cable	41

recharging the battery.....	60
video coding formats.....	137
video equipment, external	57
video title page.....	See <i>title page</i>
Video title settings	76, 77
video tools.....	112

videos

exporting	137
maximum size	105
recording	105, 108, 109, 111
recording capacity of controller.....	44
recording indicators	107
replaying.....	121

volume

adjusting.....	122
volume control screenshot.....	121

W

warning symbols	6
-----------------------	---

WiFi

connect to network	81, 139
enabling	80

network list	79
status indicators	80
switch to different network	140
wizard	See <i>setup wizard</i>
wraps around, menu scrolling	72
WRc MSSC standards	169

w-skids.....	56
--------------	----

Z

zero distance	
definition.....	19
zeroing the camera.....	103

Contact us

To see the full range of products and services provided by CUES, visit www.cuesinc.com

CUES (USA)

3600 Rio Vista Avenue, Orlando, FL 32805, USA

Toll Free: +1 (800) 327 7791

salesinfo@cuesinc.com

CUES (Canada)

2-1675 Sismet Road, Mississauga, Ontario L4W 1P9, Canada

Toll Free: +1 (877) 297 8957

larryc@cuesinc.com

Pearpoint (USA)

39-740 Garand Lane, Unit B, Palm Desert, CA 92211, USA

Tel: +1 800 688 8094 Tel: +1 760 343 7350

pearpoint.sales.us@spx.com www.pearpoint.com